

POWER CONTROLLERS



40



1



20



30



300

CHAUVIN ARNOUX GROUP

Founded in 1893 in Paris, France, **Chauvin Arnoux** has succeeded across the centuries in **developing its expertise in the design, manufacture and marketing of measurement instruments for professionals.**

From portable instrumentation to fixed electrical equipment and energy performance systems and from mastery of the entire thermal process chain through to industrial metrology, the **Chauvin Arnoux** Group's offering meets every customer requirement over all sectors (self-employed electricians, industry, government, etc.).

A few figures

- 10 subsidiaries worldwide
- 900 employees
- 7 production sites
- 6 R&D departments
- 11 % of revenues invested in R&D



4 expert measurement companies in one Group



Portable test and measurement instrumentation



Metering, measurement and energy performance



Temperature in industrial processes



Metrology and regulatory testing

PYROCONTROLE

Pyrocontrol designs high-accuracy sensors for severe environments and solutions for temperature measurement and control in all thermal process industries.

A wide range of sensors and comprehensive mastery of the industrial process chain make **Pyrocontrol** a crucial partner for the nuclear and petrochemicals industries, the glassmaking sector, metallurgy, etc.

Temperature
measurement
& control

Measurement
instrumentation

Pyrometry

Advantages

Usually driven by control loops, **thyristor solid-state relays and power controllers** handle switching of the high power levels necessary for industrial processes. They represent an advantageous alternative to power contactors. Their solid-state design means that there are no problems with wear of the contacts, as encountered with electro-mechanical systems.

This gives thyristor control systems a much longer lifetime with very rapid switching rates on large single or three-phase resistive or inductive loads and great precision. On the top-range models, advanced load limitation, control and monitoring functions make installations equipped with these devices even more reliable.

Applications

The solid-state relays and power controllers in the **THYRITOP** family can be used in multiple sectors of activity and in a wide range of applications, such as:

- Heat treatment furnaces
- Furnaces and processes for the glass industry
- Chemical and petrochemical equipment
- Retraction tunnels, paint, infrared lamps, thermoforming, drying
- Injection moulding presses, thermoforming equipment
- Industrial food extruders
- Ovens, climatic chambers, autoclaves
- Industrial dryers
- Mould preheaters, ducts

Operating mode

Principle of a thyristor solid-state relay

A thyristor is like a high-power diode which lets the current flow when it receives a control signal on a 3rd electrode, the "gate". To switch an AC current, two anti-parallel thyristors are therefore used.

The load serialized with these thyristors is controlled by means of the gate signal. This is done by electronic circuits which control the trigger according to an index signal usually transmitted by a controller.

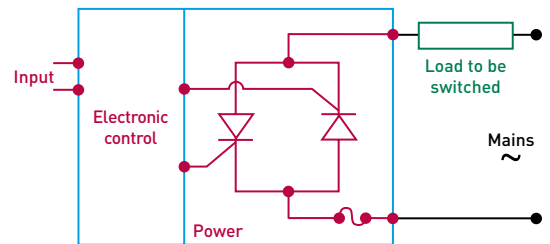

Principle of power Controllers

• Syncopated wave train or TAKT mode

Resistive loads with thermal inertia, resistors or transformer primaries.

Full wave switching, adjustment of the power by the ratio T_S/T_0 . Delayed activation when conduction is started means that inrush currents can be avoided in the transformers.

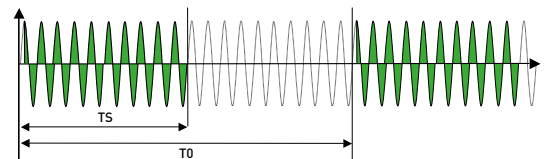

• Quick TAKT mode (QTM)

Single-phase resistive loads with low thermal inertia (infrared resistors).

Single-alternation switching with frequent energy input for good thermal stability of the heating element.

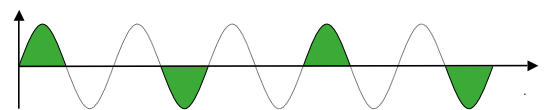

• Phase angle or VAR mode

Load with low thermal inertia, resistor or transformer primary or inductor

Adaptation of power by means of the trigger angle. Power is constant, but harmonics are present.

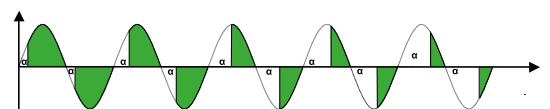

• Mixed mode (SSSD)

Resistive loads with thermal inertia, resistor or transformer primary
Gradual start of the phase-angle wave train, then full-wave conduction and gradual stop.

Adjustment of the power by means of the ratio T_S/T_0 . Limits inrush currents.

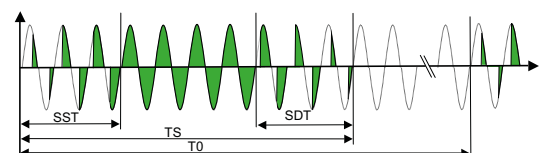

► Solid-state relays



THYRITOP 1

► page 6

THYRITOP 20

► page 7

Network		
Single-phase	■	H1 / HRL1
Current range	25 A ... 45 A	16 A, 30 A, 45 A, 60 A, 100 A, 130 A, 170 A, 280 A
Voltage range	48 V to 660 V	230 V, 400 V, 500 V
Load		
Constant resistance	■	H1 / HRL1
Operation		
On-off	■	H1 / HRL1
Control		
DC logic voltage	■	H1 / HRL1
Dry contact	-	H1 / HRL1
Functions		
Load fault detection	-	HRL1
Alarm output	-	HRL1
Communication	-	H1 / HRL1
Power fuse	-	H1 / HRL1

Identification of TH 20 models ■ ■

H built-in fast-acting fuse

R default relay output

L load monitoring

1 without display or optional display

example:

HRL1 : H: built-in fast-acting fuse -
R: default relay output - **L**: load monitoring -
1: without display or optional display

► Accessories

Multiple accessories are available to upgrade the **THYRITOPs** to meet your needs: mounting fixture, programming software, communication modules or boards ► page 17



► Selection assistance and training

Pyrocontrole at your service ► page 19

► Power controllers



	THYRITOP 30 ► page 8			THYRITOP 300 ► page 10			THYRITOP 40 ► page 12			
	1A	2A	3A	1A	2A	3A	1P	2P	3P	
Network										
Single-phase	H1 / HRL1 / HRLP1				HRLP2			HRLP1		
Three-phase, 2-phase cut-off		H1 / HRL1 / HRLP1			HRLP2			HRLP1		
Three-phase, 3-phase cut-off			H1 / HRL1 / HRLP1			HRLP2			HRLP1	
Current range	16 A ... 350 A			16 A ... 1,500 A			16 A ... 2,900 A			
Voltage range	230 V, 400 V, 500 V			230 V, 400 V, 500 V, 600 V			400 V, 500 V, 690 V			
Load										
Constant resistance	H1 / HRL1 / HRLP1			HRLP2			HRLP1			
Variable resistance	HRL1 / HRLP1			HRLP2			HRLP1			
Transformer and inductor	HRL1 / HRLP1			HRLP2			HRLP1			
Operation										
On-off	H1 / HRL1 / HRLP1	H1 / HRL1 / HRLP1	H1 / HRL1 / HRLP1	HRLP2	HRLP2	HRLP2	HRLP1	HRLP1	HRLP1	
TAKT	H1 / HRL1 / HRLP1	H1 / HRL1 / HRLP1	H1 / HRL1 / HRLP1	HRLP2	HRLP2	HRLP2	HRLP1	HRLP1	HRLP1	
QTM	H1 / HRL1 / HRLP1			HRLP2						
Phase angle	H1 / HRL1 / HRLP1		H1 / HRL1 / HRLP1	HRLP2		HRLP2	HRLP1		HRLP1	
Mixed							HRLP1	HRLP1	HRLP1	
Control										
Analogue input	H1 / HRL1 / HRLP1			HRLP2			HRLP1			
Potentiometric input	H1 / HRL1 / HRLP1			HRLP2			HRLP1			
Digital input	H1 / HRL1 / HRLP1			HRLP2			HRLP1			
Functions										
Control of	U, U ²	H1 / HRL1 / HRLP1			HRLP2			HRLP1		
	I, I ²	HRL1 / HRLP1			HRLP2			HRLP1		
	P	HRLP1			HRLP2			HRLP1		
Limitation of	U	H1 / HRL1 / HRLP1			HRLP2			HRLP1		
	I	HRL1 / HRLP1			HRLP2			HRLP1		
	P	HRLP1			HRLP2			HRLP1		
Retransmission	HRL1 / HRLP1			HRLP2			HRLP1			
Load fault detection	HRL1 / HRLP1			HRLP2			HRLP1			
Diagnosis	HRL1 / HRLP1			HRLP2			HRLP1			
Alarm	HRL1 / HRLP1			HRLP2			HRLP1			
Synchronization	H1 / HRL1 / HRLP1			HRLP2			HRLP1			
Communication	H1 / HRL1 / HRLP1			HRLP2			HRLP1			
Power fuses	H1 / HRL1 / HRLP1			HRLP2			HRLP1			

Identification of models



H	built-in fast-acting fuse	P	power control
R	default relay output	1	without display or optional display
L	load monitoring	2	built-in display

example:

HRLP2 : H: built-in fast-acting fuse -
R: default relay output - L: load monitoring -
P: power control - 2: built-in display

Solid-state relays | THYRITOP 1

PRODUCT ADVANTAGES

- Economical
- DIN-rail or plate mounting
- Available in stock
- Direct control by our STATOP* controllers



Description

The **THYRITOP 1** is a single-phase solid state relay with electronic control for resistive loads, $R_{hot} / R_{cold} = 1$. These **very compact units** are particularly **simple** to mount (DIN rail or plate) and can be connected via screw terminals.

They enable **very rapid On-Off load control**.

On-off operation

If a voltage is applied on the input, the electronic circuit commands the two anti-parallel thyristors, according to the wave train principle, which means that this solid-state relay is opened and closed at the zero voltage.

If there is no control signal, the thyristors are blocked.

Connection on screw terminals

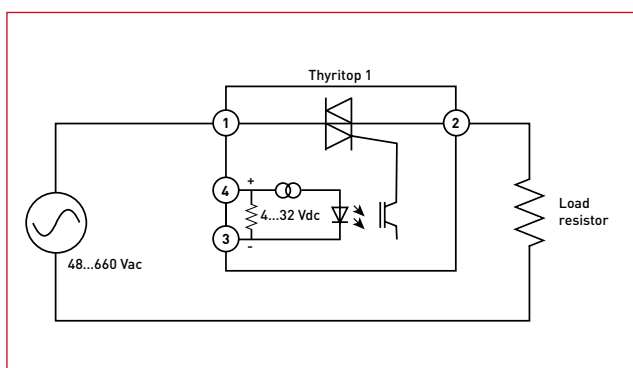

Power circuit

Rated current	25 A and 45 A depending on model
Operating voltage	48 to 660 V _{AC} , single-phase
Network frequency	47 to 63 Hz
Three-phase load control	<ul style="list-style-type: none"> • 2-phase cut-off for load without neutral with 2 THYRITOP 1 models • 3-phase cut-off for load with neutral with 3 THYRITOP 1 models
Dielectric strength	2.5 kV

Control circuit

Control	DC logic voltage 0 V < OFF < 1 V 4 V < ON < 32 V
Voltage drop	1.6 V
Indication	LED (control signal)
Input resistance	3 kΩ
Response time	closure: 0.5 period maximum opening: 0.5 period maximum

General specifications

Input/output insulation	4 kV
Protection	IP 20
Installation conditions	vertical mounting
Min. distance between 2 relays	22 mm for the 25 A model 45 mm for the 45 A model
Climatic conditions	-20 °C...+80 °C
Compliance	CE

Dimensions

Model	Dimensions (mm)			Weight (g)
	L	H	W	
25 A	22,5	98	102,8	250
45 A	45	98	102,8	490

Related products

*STATOP digital temperature controllers.
More than 200 models referenced.

► Please contact us.



REFERENCES

THYRITOP 1 - 48 to 660 V - 25 A	P01646001
THYRITOP 1 - 48 to 660 V - 45 A	P01646002

Solid-state relays | THYRITOP 20



PRODUCT ADVANTAGES

- Resistive loads
- Use from 110 VAC to 500 VAC and from 16 A to 280 A
- Built-in ultra-fast fuse
- Direct control by our STATOP* controllers
- Digital communication via bus modules

► Description / Operation in On-off mode

Same as **THYRITOP 1**

► Power circuit

Power circuit	Single-phase
Rated current	16 A to 280 A depending on model
Rated voltage	230 V, 400 V, 500 V
Network frequency	47 to 63 Hz
Operating voltage	<ul style="list-style-type: none"> • -15 % / +10 % of rated voltage • -57 % / +10 % of rated voltage with auxiliary power supply (HRL1 model)
Three-phase load control	<ul style="list-style-type: none"> • 2-phase cut-off for load without neutral with 2 THYRITOP 20 models • 3-phase cut-off for load with neutral with 3 THYRITOP 20 models

► Control circuit

Control	<ul style="list-style-type: none"> • DC logic voltage 0 V < OFF < 1 V 3 V < ON < 24 V • Dry contact • Digital via bus module
Indication	<ul style="list-style-type: none"> ON LED Load fault LED Internal control signal LED
Input resistance	3.3 kΩ

► General specifications

Supervision	<ul style="list-style-type: none"> • Internal faults • Blown fuse • Partial load fault (HRL1)
Alarm	250 V/ 6 A relay (HRL1)
Fault indication	Load fault LED (HRL1)
Configuration	Micro-switch, and potentiometers or THYRITOP-Tool software
Insulation	As per EN 50178
Protection	IP 20
Installation conditions	Vertical mounting, power connection at bottom
Climatic conditions	<ul style="list-style-type: none"> • -10 °C... +45 °C unventilated models • -10 °C... +40 °C HF models • -10 °C... +55 °C at reduced current [-2 % of rated current per °C]
Compliance	CE + UL

► Accessories and related products

- Mounting fixture, programming software, communication modules. ► page 17
- *STATOP digital temperature controllers. More than 200 models referenced. ► Please contact us.



► Application diagram

THYRITOP 20 single-phase models (1S)

- For HRL1 models only
- For 280 A models only. 230 V fan power supply.

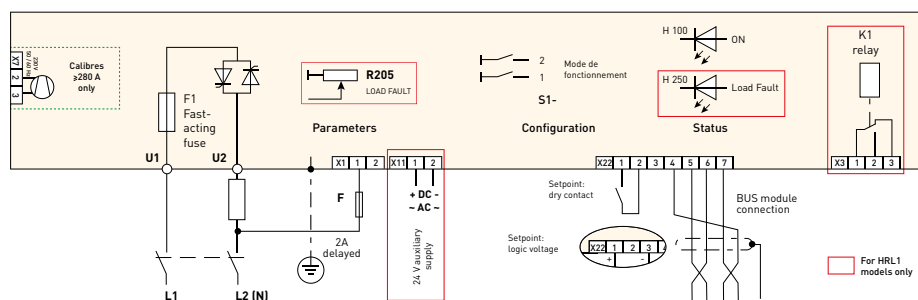

REFERENCES

1S: Single-phase	Rated current (A)	Rated voltage (V)									Power dissipation (W)	Fuse (A)	Dimensions (mm)			Weight (kg)
		230 V			400 V			500 V					L	H	W	
		Rated power (kW)	H1 model ref.	HRL1 model ref.	Rated power (kW)	H1 model ref.	HRL1 model ref.	Rated power (kW)	H1 model ref.	HRL1 model ref.						
16	3.7	P01646522	P01646549	6.4	P01646531	P01646558	8	P01646540	P01646567	30	20	45	131	127	0.7	
30	6.9	P01646523	P01646550	12	P01646532	P01646559	15	P01646541	P01646568	47	40	45	131	127	0.7	
45	10	P01646524	P01646551	18	P01646533	P01646560	22.5	P01646542	P01646569	48	63	52	190	182	1.7	
60	14	P01646525	P01646552	24	P01646534	P01646561	30	P01646543	P01646570	80	100	52	190	182	1.7	
100	23	P01646526	P01646553	40	P01646535	P01646562	50	P01646544	P01646571	105	180	75	190	190	1.9	
130	30	P01646527	P01646554	52	P01646536	P01646563	65	P01646545	P01646572	150	200	125	320	237	4	
170	39	P01646528	P01646555	68	P01646537	P01646564	85	P01646546	P01646573	210	315	125	320	237	4	
280F	64	P01646529	P01646556	112	P01646538	P01646565	140	P01646547	P01646574	330	350	125	370	237	5	

(F): Model equipped with fans

PRODUCT ADVANTAGES

- Resistive and inductive loads
- Use from 110 VAC to 500 VAC and from 16 A to 350 A
- Built-in ultra-fast fuse
- Multiple functions as standard
- Digital communication via modules



Description

The **THYRITOP 30** models are solid-state power controllers with electronic control for all types of resistive or inductive, single-phase or three-phase loads.

Operation

The **THYRITOP 30** can operate in three modes:

- syncopated wave train mode (TAKT),
- fast syncopated wave train mode (QTM),
- phase-angle variation mode (VAR).

You can switch very simply between these three modes by means of a micro-switch or by software configuration. This means that users can adapt it to any type of power control, such as resistors with a high hot/cold coefficient, silicon carbide, molybdenum, tantalum, tungsten, primary windings of transformers, etc.

H1 models: resistive loads ($R_{hot} / R_{cold} = 1$)
inductive loads ($B < 1.2 T$)

HRL(P)1 models: resistive loads ($R_{hot} / R_{cold} \leq 6$)
inductive loads ($B < 1.2 T$)

Power circuit

Power circuit	Single-phase or three-phase with 2 or 3-phase cut-off
Rated current	16 A to 350 A
Rated voltage	230 V, 400 V, 500 V
Network frequency	47 to 63 Hz
Operating voltage	<ul style="list-style-type: none"> • -15 % / +10 % of rated voltage • -57 % / +10 % of rated voltage with auxiliary power supply (HRL1 model).

Control circuit

Analogue	2 configurable analogue inputs: <ul style="list-style-type: none"> • 0/4...20 mA ($R_i = 250 \Omega$) • 0...5 V ($R_i = 44 k\Omega$) • 0...10 V ($R_i = 88 k\Omega$)
Potentiometric	5 k Ω to 10 k Ω
Digital	Via bus module
Other	Logic input for start-up authorization

General specifications

Control	<ul style="list-style-type: none"> • U and U² to $\pm 2.5 \%$ • I and I² to $\pm 1.5 \%$ (HRL1) • P to $\pm 3 \%$ (HRLP1) • No control
Supervision	<ul style="list-style-type: none"> • Internal faults • Under or overvoltage • Partial load fault (HRL1) • Under or overcurrent (HRL1)
Alarm	Relay (HRL1)
Fault indication	3 LEDs: fuse, ΔI , ΔU
Retransmission	1 analogue output, 0...10 V or 0/4... 20 mA (HRL1)
Auxiliary power supply	24 VAC/DC (HRL1)
Configuration	Microswitch and potentiometers or THYRITOP-Tool software
Insulation	As per EN50178
Protection	IP 20
Installation conditions	Vertical mounting and power connection at bottom
Climatic conditions	<ul style="list-style-type: none"> • -10 °C...+45 °C unventilated models • -10 °C...+35 °C HF.. models • -10 °C...+55 °C with reduced current [- 2 % of rated current per °C]
Compliance	CE + UL

Selection guide

	THYRITOP 30		
	1A	2A	3A
Network			
Single-phase	■		
Three-phase, 2-phase cut-off		■	
Three-phase, 3-phase cut-off			■
Voltage range	230 V, 400 V, 500 V		
Current range	16 A ... 350 A		
Load			
Constant resistance	■		
Variable resistance		■	
Transformer and inductor			■
Operation			
On-off	■	■	■
Syncopated wave train	■	■	■
Fast syncopated wave train	■		
Phase angle	■		■
Control			
Analogue input		■	
Potentiometric input		■	
Digital input		■	
Functions			
U, U ² control / limitation		■	
I, I ² control / limitation		■	
P control / limitation		■	
Retransmission		■	
Load fault detection		■	
Diagnosis		■	
Alarm		■	
Synchronization		■	
Communication		■	
Power fuses		■	

■ = H1 / HRL1 / HRLP1 ■ = HRL1 / HRLP1 ■ = HRLP1

► Application diagram

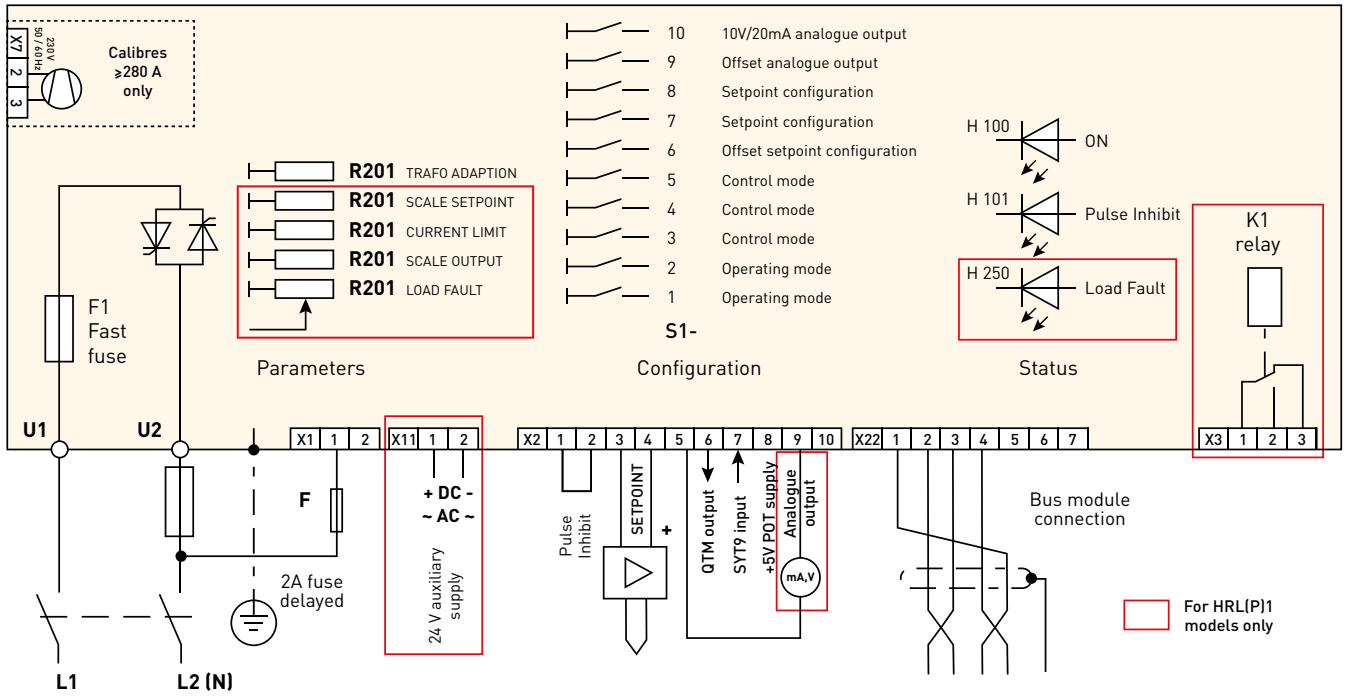

Single-phase THYRITOP 30 models (1A)

► Accessories

Mounting fixture, programming software, communication modules. ► page 17

REFERENCES

Circuit	Rated current (A)	Rated voltage (V)												Power dissipation (W)	Fuse (A)	Dimensions (mm)			Weight (kg)
		230 V			400 V			500 V			L	H	W						
		Rated power (kW)	H1 model ref.	HRL1 model ref.	HRLP1 model ref.	Rated power (kW)	H1 model ref.	HRL1 model ref.	HRLP1 model ref.	Rated power (kW)						H1 model ref.	HRL1 model ref.	HRLP1 model ref.	
1A: Single-phase	16	3,7	P01646802	P01646829	P01646421	6,4	P01646811	P01646838	P01646431	8	P01646820	P01646847	P01646441	30	20	45	131	127	0,7
	30	6,9	P01646803	P01646830	P01646422	12	P01646812	P01646839	P01646432	15	P01646821	P01646848	P01646442	47	40	45	131	127	0,7
	45	10	P01646804	P01646831	P01646423	18	P01646813	P01646840	P01646433	22,5	P01646822	P01646849	P01646443	48	63	52	190	182	1,7
	60	14	P01646805	P01646832	P01646424	24	P01646814	P01646841	P01646434	30	P01646823	P01646850	P01646444	80	80	52	190	182	1,7
	100	23	P01646806	P01646833	P01646425	40	P01646815	P01646842	P01646435	50	P01646824	P01646851	P01646445	105	200	75	190	190	1,9
	130	30	P01646807	P01646834	P01646426	52	P01646816	P01646843	P01646436	65	P01646825	P01646852	P01646446	150	200	125	320	237	4
	170	39	P01646808	P01646835	P01646427	68	P01646817	P01646844	P01646437	85	P01646826	P01646853	P01646447	210	315	125	320	237	4
	280 F	64	P01646809	P01646836	P01646428	112	P01646818	P01646845	P01646438	140	P01646827	P01646854	P01646448	330	350	125	370	237	5
350 F	81	P01646810	P01646837	P01646430	140	P01646819	P01646846	P01646440	175	P01646828	P01646855	P01646450	430	500	125	400	261	8,4	
2A: Three-phase, 2-phase cut-off	16	-	-	-	11	P01646856	P01646874	P01646451	14	P01646865	P01646883	P01646461	60	20	90	131	127	1,4	
	30	-	-	-	21	P01646857	P01646875	P01646452	26	P01646866	P01646884	P01646462	94	40	90	131	127	1,4	
	45	-	-	-	31	P01646858	P01646876	P01646453	39	P01646867	P01646885	P01646463	96	63	104	190	182	3,4	
	60	-	-	-	42	P01646859	P01646877	P01646454	52	P01646868	P01646886	P01646464	160	80	104	190	182	3,4	
	100	-	-	-	69	P01646860	P01646878	P01646455	87	P01646869	P01646887	P01646465	210	200	150	190	190	3,8	
	130	-	-	-	90	P01646861	P01646879	P01646456	112	P01646870	P01646888	P01646466	300	200	250	320	237	8	
	170	-	-	-	118	P01646862	P01646880	P01646457	147	P01646871	P01646889	P01646467	420	315	250	320	237	8	
	280 F	-	-	-	194	P01646863	P01646881	P01646458	242	P01646872	P01646890	P01646468	660	350	250	393	237	11	
350 F	-	-	-	242	P01646864	P01646882	P01646460	303	P01646873	P01646420	P01646469	860	500	250	430	261	16,7		
3A: Three-phase, 3-phase cut-off	16	-	-	-	11	P01647000	P01647018	P01647036	14	P01647009	P01647027	P01647045	90	20	135	131	127	2,1	
	30	-	-	-	21	P01647001	P01647019	P01647037	26	P01647010	P01647028	P01647046	141	40	135	131	127	2,1	
	45	-	-	-	31	P01647002	P01647020	P01647038	39	P01647011	P01647029	P01647047	144	63	156	190	182	5,1	
	60	-	-	-	42	P01647003	P01647021	P01647039	52	P01647012	P01647030	P01647048	240	80	156	190	182	5,1	
	100	-	-	-	69	P01647004	P01647022	P01647040	87	P01647013	P01647031	P01647049	315	200	225	190	190	5,7	
	130	-	-	-	90	P01647005	P01647023	P01647041	112	P01647014	P01647032	P01647050	450	200	375	320	241	12	
	170	-	-	-	118	P01647006	P01647024	P01647042	147	P01647015	P01647033	P01647051	630	315	375	320	241	12	
	280 F	-	-	-	194	P01647007	P01647025	P01647043	242	P01647016	P01647034	P01647052	990	350	375	397	241	15	
350 F	-	-	-	242	P01647008	P01647026	P01647044	303	P01647017	P01647035	P01647053	1170	500	375	430	261	25,5		

(F): Model equipped with fans

Power controllers | THYRITOP 300

PRODUCT ADVANTAGES

- Resistive and inductive loads
- Use from 24 VAC to 600 VAC and from 16 A to 1,500 A
- Built-in ultra-fast fuse
- Built-in human-machine interface
- Power connection via top or bottom
- Digital communication via bus module

NEW



Description

The **THYRITOP 300** models represent the latest generation of power controllers for all types of resistive or inductive loads.

Operation

The **THYRITOP 300** can operate in four modes:

- On-off (SWITCH),
- Syncopated wave train (TAKT),
- Fast syncopated wave train (QTM),
- Phase-angle variation (VAR).

These modes can be configured via the graphical interface or via software.

This ensures that **users can adapt to all types of power control**, such as resistors with a significant hot/cold coefficient, silicon carbide, molybdenum, tantalum, tungsten, transformer primaries, etc.

Power circuit

Circuit	Single-phase or three-phase with 2 or 3-phase cut-off
Rated current	16 A to 1,500 A
Rated voltage	230 V, 400 V, 500 V, 600 V
Network frequency	47 to 63 Hz
Operating voltage	From 24 VAC up to the rated voltage +10 %

Control circuit

Analogue	2 configurable analogue inputs: <ul style="list-style-type: none"> • 0/4...20 mA (Ri = 250 Ω) • 0...5 V (Ri = 44 kΩ) • 0...10 V (Ri = 88 kΩ)
Potentiometric	5 kΩ to 10 kΩ
Digital	Via bus module
Other	Logic input for start-up authorization

General specifications

Control	<ul style="list-style-type: none"> • U and U² to ± 1.5 % • I and I² to ± 1.5 % • P to ± 3 % • No control
Supervision	<ul style="list-style-type: none"> • Internal faults • Partial load fault • Under or overvoltage • Under or overcurrent • Excessive temperature • Fuse blown, etc.

Alarm	1 x relay (250 V / 4 A), configurable
Fault indication	Display on graphical interface + error message
Recording	Up to 64 time/date-stamped events (real-time clock)
Retransmission	3 x configurable analogue outputs (0...10 V or 0/4... 20 mA)
Auxiliary inputs / outputs	3 configurable logic inputs/outputs
Auxiliary power supply	110/230 VAC (85-265 VAC)
Voltage / current measurements	<ul style="list-style-type: none"> • Internal transformers • Possibility of wiring external transformers
Configuration	Via the graphical interface or the THYRITOP-Tool 300 software
USB interface	For PC connection (THYRITOP-Tool 300) and back-up/loading of parameters on USB stick
Ethernet interface	For PC connection (Thyritop-Tool 300), built-in Web server for viewing the values in real time
Insulation	As per EN 50178
Protection	IP 20
Installation conditions	Vertical mounting and power connection at top or bottom
Climatic conditions	<ul style="list-style-type: none"> • Rated current from -10 °C to +40 °C • Reduced current up to +55 °C [-2 % of current per additional °C]
Compliance	CE + UL

Selection guide

	THYRITOP 300		
	1A	2A	3A
Network			
Single-phase	■		
Three-phase, 2-phase cut-off		■	
Three-phase, 3-phase cut-off			■
Voltage range	230 V, 400 V, 500 V, 600 V		
Current range	16 A ... 1,500 A		
Load			
Constant resistance		■	
Variable resistance		■	
Transformer and inductor		■	
Operation			
On-off	■	■	■
Syncopated wave train	■	■	■
Fast syncopated wave train	■		
Phase angle	■		■
Control			
Analogue input		■	
Potentiometric input		■	
Digital input		■	
Functions			
U, U ² control / limitation		■	
I, I ² control / limitation		■	
P control / limitation		■	
Retransmission		■	
Load fault detection		■	
Diagnosis		■	
Alarm		■	
Synchronization		■	
Communication		■	
Power fuses		■	

■ = HRLP2

► Application diagram

THYRITOP 300 models with 2-phase cut-off (2A)

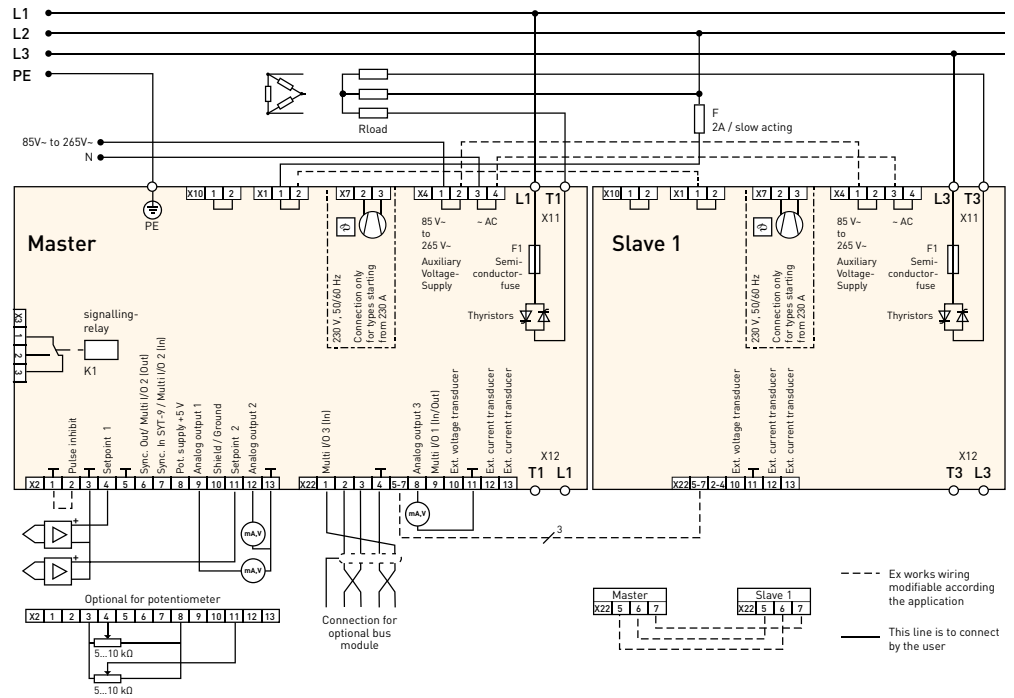

► Accessories

Mounting fixture, programming software, communication modules

► page 17

REFERENCES

Circuit	Rated current (A)	Rated voltage (V)						Power dissipation (W)	Fuse (A)	Dimensions (mm)			Weight (kg)		
		230 V		400 V		500 V				600 V		L		H	W
		Rated power (kW)	HRLP2 model ref.	Rated power (kW)	HRLP2 model ref.	Rated power (kW)	HRLP2 model ref.			Rated power (kW)	HRLP2 model ref.				
1A: Single-phase	16	3.7	P01641050	6.4	P01641060	8	P01641074	-	25	20	45	196	193	1.1	
	30 F	6.9	P01641051	12	P01641061	15	P01641075	-	40	40	45	196	193	1.1	
	45	11	P01641052	18	P01641062	23	P01641076	27	P01641088	60	63	52	276	238	2.2
	60	14	P01641053	24	P01641063	30	P01641077	36	P01641089	70	100	52	276	238	2.2
	100 F	23	P01641054	40	P01641064	50	P01641078	60	P01641090	130	180	54	276	238	2.8
	130	30	P01641055	52	P01641065	65	P01641079	78	P01641091	180	200	125	361	283	7.8
	170	39	P01641056	68	P01641066	85	P01641080	102	P01641092	210	315	125	361	283	7.8
	230 F	53	P01641057	92	P01641067	115	P01641081	-	280	315	125	373	283	8.3	
	240 F	-	-	-	-	-	-	138	P01641093	330	315	125	373	283	8.3
	280 F	64	P01641058	112	P01641068	140	P01641082	-	350	350	125	373	283	8.3	
	350 F	81	P01641059	140	P01641069	175	P01641083	210	P01641094	400	500	125	373	283	8.3
	495 F	-	198	P01641070	248	P01641084	297	P01641095	610	630	180	640	395	20	
	650 F	-	260	P01641071	325	P01641085	390	P01641096	740	900	180	640	395	20	
	1000 F	-	400	P01641072	500	P01641086	600	P01641097	1400	2 x 1000	285	550	565	33.5	
	1400 F	-	-	-	700	P01641087	840	P01641098	1700	4 x 900	285	550	565	33.5	
1500 F	-	600	P01641073	-	-	-	-	1770	4 x 900	285	550	565	33.5		
2A: Three-phase, 2-phase cut-off	16	-	-	11	P01641138	14	P01641152	-	50	20	90	196	193	2.2	
	30 F	-	-	21	P01641139	26	P01641153	-	80	40	90	196	193	2.2	
	45	-	-	31	P01641140	39	P01641154	47	P01641166	120	63	108	276	238	4.4
	60	-	-	42	P01641141	52	P01641155	62	P01641167	150	100	108	276	238	4.4
	100 F	-	-	69	P01641142	87	P01641156	104	P01641168	260	180	110	276	238	5.6
	130	-	-	90	P01641143	112	P01641157	135	P01641169	360	200	250	361	283	15.6
	170	-	-	118	P01641144	147	P01641158	177	P01641170	420	315	250	361	283	15.6
	230 F	-	-	159	P01641145	199	P01641159	-	560	315	250	373	283	16.6	
	240 F	-	-	-	-	-	240	P01641171	670	315	250	373	283	16.6	
	280 F	-	194	P01641146	243	P01641160	-	-	700	350	250	373	283	16.6	
	350 F	-	243	P01641147	303	P01641161	364	P01641172	800	500	250	373	283	16.6	
	495 F	-	342	P01641148	429	P01641162	514	P01641173	1200	630	256	640	395	28.5	
	650 F	-	450	P01641149	563	P01641163	676	P01641174	1460	900	256	640	395	28.5	
	1000 F	-	693	P01641150	866	P01641164	1040	P01641175	2820	2 x 1000	452	550	565	53	
	1400 F	-	-	-	1212	P01641165	1455	P01641176	3470	4 x 900	452	550	565	53	
1500 F	-	1040	P01641151	-	-	-	-	3550	4 x 900	452	550	565	53		
3A: Three-phase, 3-phase cut-off	16	-	-	11	P01641216	14	P01641230	-	75	20	135	196	193	3.3	
	30 F	-	-	21	P01641217	26	P01641231	-	120	40	135	196	193	3.3	
	45	-	-	31	P01641218	39	P01641232	47	P01641244	180	63	164	276	238	6.6
	60	-	-	42	P01641219	52	P01641233	62	P01641245	220	100	164	276	238	6.6
	100 F	-	-	69	P01641220	87	P01641234	104	P01641246	390	180	164	276	238	8.4
	130	-	-	90	P01641221	112	P01641235	135	P01641247	540	200	375	361	283	23.4
	170	-	-	118	P01641222	147	P01641236	177	P01641248	550	315	375	361	283	23.4
	230 F	-	-	159	P01641223	199	P01641237	-	840	315	375	373	283	24.9	
	240 F	-	-	-	-	-	240	P01641249	1000	315	375	373	283	24.9	
	280 F	-	194	P01641224	243	P01641238	-	-	1050	350	375	373	283	24.9	
	350 F	-	243	P01641225	303	P01641239	364	P01641250	1200	500	375	373	283	24.9	
	495 F	-	342	P01641226	429	P01641240	514	P01641251	1840	630	344	640	395	37	
	650 F	-	450	P01641227	563	P01641241	676	P01641252	2200	900	344	640	395	37	
	1000 F	-	693	P01641228	866	P01641242	1040	P01641253	4150	2 x 1000	618	550	565	72	
	1400 F	-	-	-	1212	P01641243	1455	P01641254	5100	4 x 900	618	550	565	72	
1500 F	-	1040	P01641229	-	-	-	-	5200	4 x 900	618	550	565	72		

(F): Model equipped with fans

PRODUCT ADVANTAGES

- Resistive and inductive loads
- Use from 230 VAC to 690 VAC and from 37 A to 2,900 A
- Built-in ultra-fast fuse
- Model with 1, 2 or 3-phase cut-off
- Configurable via LBA graphical unit or **THYRITOP-Tool** software
- Colour LBA2 touch screen which can be integrated on the power switch or used remotely
- Three analogue outputs and three configurable relays
- Energy meter and recording of events
- ASM and dASM anti-flicker system
- Digital communication via daughter boards



► Description

The **THYRITOP 40** models are latest-generation communicating power controllers. They are **specially designed for controlling resistive or inductive loads** in single-phase mode (1P), three-phase mode with two-phase cut-off (2P) or three-phase mode with three-phase cut-off (3P). **Their compact dimensions and modularity** make them **easier to set up and simplify maintenance**.

► Operation

- The built-in electronic system is designed for control by wave train or phase angle or in mixed mode.
- The MOSI mode, a combination of the TAKT and VAR modes, can be used with the **THYRITOP 40** - 1P or 3P models. It is ideal for loads with a high R_{hot} / R_{cold} coefficient made of sensitive materials such as molybdenum disilicide by limiting the current peaks.
- Resistive loads ($R_{hot} / R_{cold} \leq 20$)
- Inductive loads ($B < 1.45$ T)
- Modulation period (TAKT and SSSD modes) adjustable from 20 to 5,000 ms.
- 100%-digital configuration can be performed:
 - Either via the LBA (plug-in or remote graphical interface)
 - Or with a PC via the RS232 link and the **THYRITOP Tool** software.

► Power circuit

Rated current	37 A to 2,900 A
Rated voltage	400 V, 500 V, 690 V
Network frequency	47 Hz to 63 Hz
Operating voltage	400 V model: 230 V [-20 %] to 400 V [+10 %]
	500 V model: 230 V [-20 %] to 500 V [+10 %]
	690 V model: 500 V [-20 %] to 690 V [+10 %]

► Control circuit

The **THYRITOP 40** offers four possibilities for setpoint inputs.

Setpoint 1	Analogue: - 0/4... 20 mA ($R_i = 60 \Omega$) by default - 0... 5 V ($R_i = 30 \text{ k}\Omega$) - 0... 10 V ($R_i = 10 \text{ k}\Omega$)
Setpoint 2	Same as Setpoint 1 (0...10 V by default)
Setpoint 3	Digital, via communication bus
Setpoint 4	Digital, for manual setpoint via LBA or digital potentiometric input
Operations	<ul style="list-style-type: none"> • Each setpoint can be activated/deactivated • Addition, subtraction, multiplication between the 4 setpoints

► Selection guide

	THYRITOP 40		
	1A	2A	3A
Network			
Single-phase	■		
Three-phase, 2-phase cut-off		■	
Three-phase, 3-phase cut-off			■
Voltage range	37 A... 2,900 A		
Current range	400 V, 500 V, 690 V		
Load			
Constant resistance		■	
Variable resistance		■	
Transformer and inductor		■	
Operation			
On-off	■	■	■
Syncopated wave train	■	■	■
Phase angle	■		■
Mixed	■	■	■
Control			
Analogue input		■	
Potentiometric input		■	
Digital input		■	
Functions			
U, U^2 / I , I^2 / P control		■	
U / I / P limitation		■	
Retransmission		■	
Load fault detection		■	
Diagnosis		■	
Alarm		■	
Synchronization		■	
Communication		■	
Power fuses		■	

■ = HRLP1

► General specifications

Control	<ul style="list-style-type: none"> • U and U² to ± 0.5 % • I and I² to ± 0.5 % • P to ± 1 % • No control
Limitation	<ul style="list-style-type: none"> • Voltage / Current / Peak current / Power • Independent of the control • Min. and Max. operating points
Supervision	<ul style="list-style-type: none"> • Internal faults • Partial load fault • Under or overvoltage • Under or overcurrent • Excessive temperature • Fuse blown, etc.
Alarm	3 configurable relays (250 V / 4 A)
Fault indication	6 LEDs on front panel Display on graphical interface (optional)
Recording	Up to 64 time/date-stamped events (real-time clock)
Retransmission	3 configurable analogue outputs (0...10 V or 0/4... 20 mA)

Auxiliary inputs / outputs	3 configurable logic inputs/outputs
Auxiliary power supply	Wideband power supply, 185 VAC-550 VAC <ul style="list-style-type: none"> • 400 V-500 V models: optional • 690 V models: mandatory
Voltage / current measurements	<ul style="list-style-type: none"> • Internal transformers • Possibility of wiring external transformers
Configuration	<ul style="list-style-type: none"> • Via the LBA2 graphical interface • Via the THYRITOP-Tool software (RS232 link)
Insulation	As per EN 50178
Installation conditions	<ul style="list-style-type: none"> • Vertical mounting • Power connection at bottom
Climatic conditions	<ul style="list-style-type: none"> • -10 °C...+45 °C unventilated models • -10 °C...+35 °C HF models • -10 °C...+55 °C with reduced current (-2 % of rated current per °C)
Compliance	CE + UL

► LBA2 graphical interface

New-generation graphical interface for simple, intuitive navigation



- **Colour touch screen**
- **Display of up to 6 quantities simultaneously** as bargraphs, instantaneous values or curves
- **Recording of the curves** for processing later on
- Configuration facilitated by question-and-answer dialogue in the **“Easy Start”** menu
- **Equipped with internal storage** for saving the parameters. Particularly useful for reconfiguring or cloning controllers.
- **Remote display:** a connection kit allows users to mount the LBA2 on the front panel of a cabinet

► Accessories

Mounting fixture, configuration software, communication boards ► page 17

► Anti-Flicker solution: optimize your network load

dASM synchronization

For installations comprising several **THYRITOP 40** units, it is possible to adjust the moment when each of them closes. Included as a standard feature, this function allows smoothing of the network power, thus optimizing energy consumption. The **anti-flicker system** significantly reduces the current peaks due to simultaneous closure of several power controllers configured in TAKT mode.

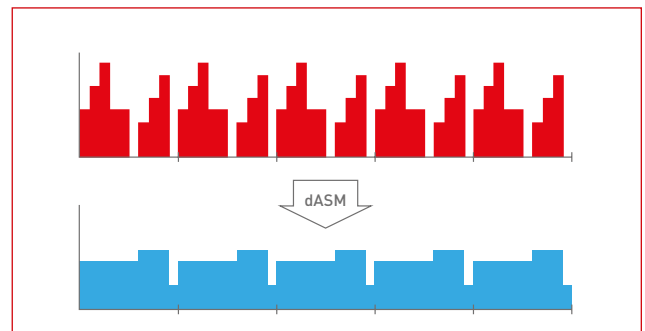

Supervision functions are available to enable flagging of information (e.g. a relay indicating that the authorized power has been exceeded) or even power cut-off functions to avoid exceeding the maximum network power (e.g. by limiting or totally shutting down non-priority zones). As a standard feature on all the **THYRITOP 40** units, this can be used to synchronize up to 24 **THYRITOP 40** units connected to the same electrical network. They can be connected very simply with RJ45 cables, allowing distances of up to 100 m between units.

ASM synchronization

The analogue ASM solution used previously is still available as an option ► page 19

► **Application diagram**

THYRITOP 40-3P model (3 phases controlled)

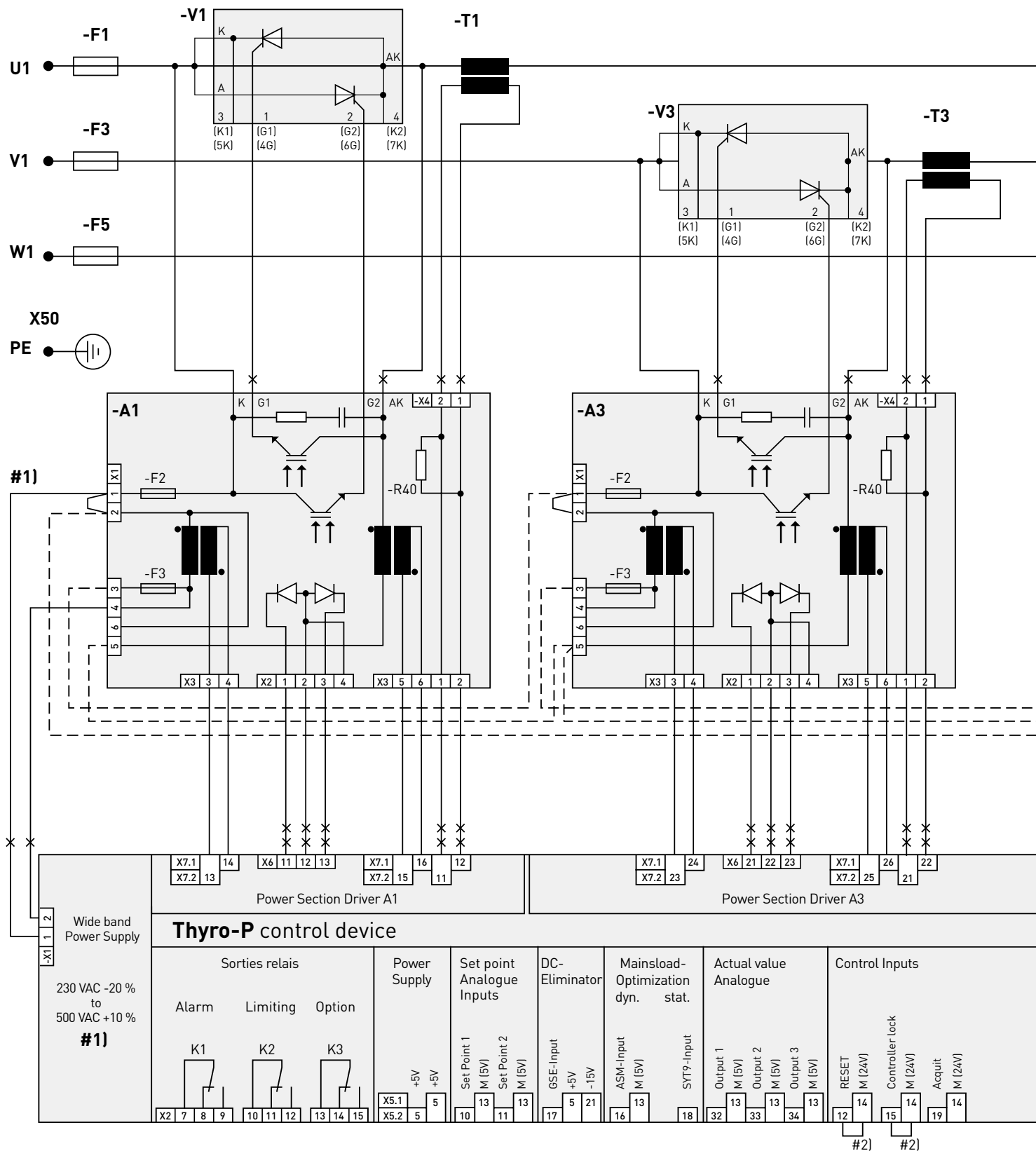

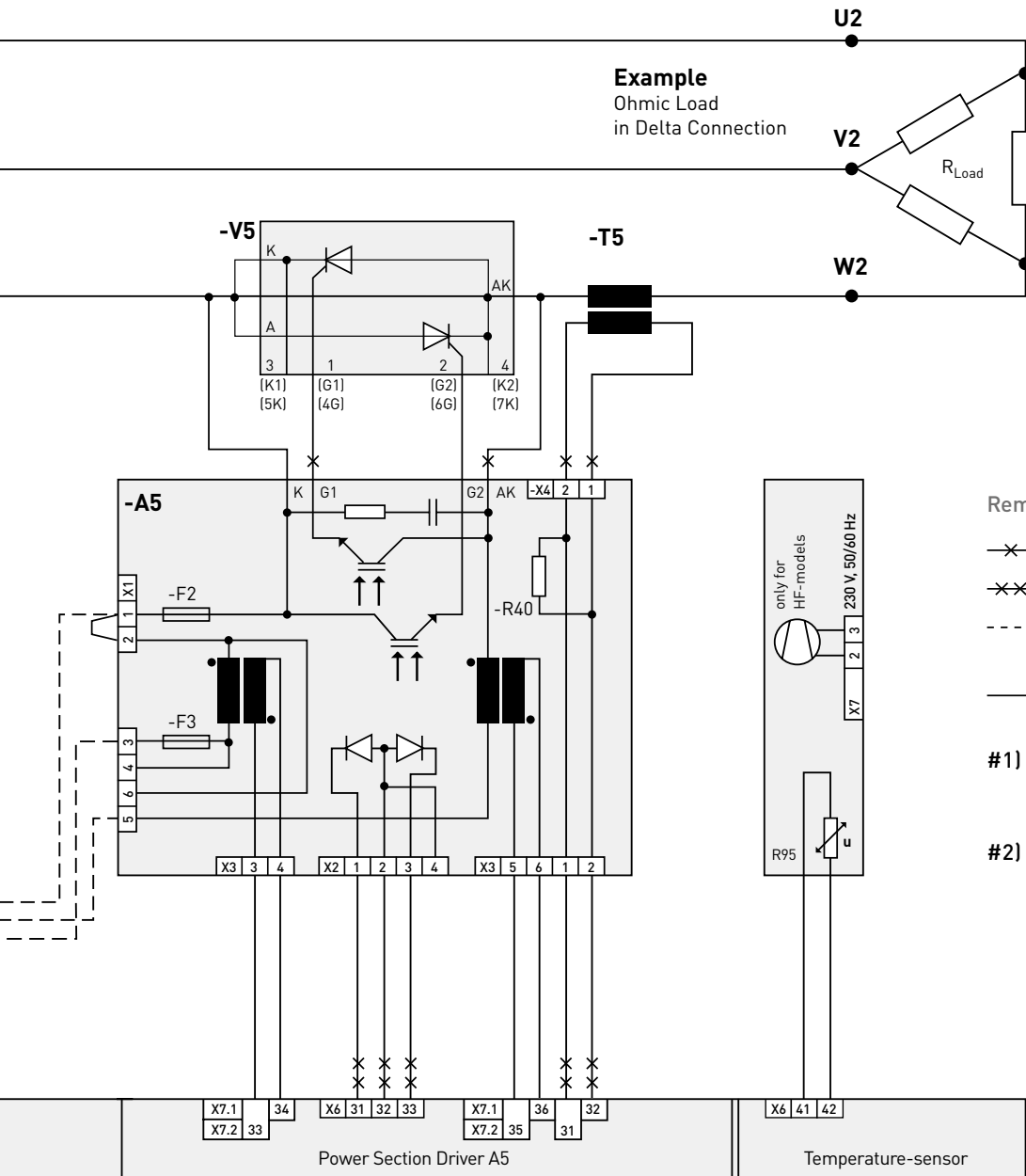

Example
Ohmic Load
in Delta Connection

Remarks

- x— Reinforced insulated wire
- x—x— Line with double insulation
- - - Standard wiring may be modified according the application
- This required line is to connect by the user
- #1)** - Separate supply is required for 690 V- Types.
- Possible for all other types.
- #2)** Delivery status

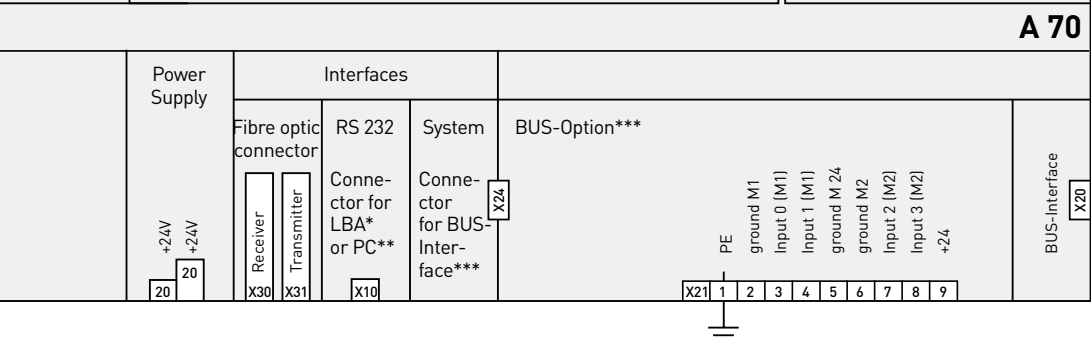

* LBA, Local Operating and Display Unit, Option
 ** PC with Thyro-Tool P Software, Option
 *** e.g. Profibus DP, Modbus RTU, Option

REFERENCES

Circuit	Rated current (A)	Rated voltage (V)						Power dissipation (W)	Fuse (A)	Dimensions (mm)			Weight (kg)
		400 V		500 V		690 V				L	H	D	
		Rated power (kW)	HRLP1 model ref.	Rated power (kW)	HRLP1 model ref.	Rated power (kW)	HRLP1 model ref.						
1P: Single-phase	37	15	P01646701	19	P01646713	-	105	50	150	320	229	6	
	75	30	P01646702	38	P01646714	-	130	100	150	320	229	6	
	80	-	-	-	-	55	P01646725	125	100	200	320	229	8
	110	44	P01646703	56	P01646715	-	175	180	150	320	229	6	
	130	52	P01646704	65	P01646716	-	190	200	200	320	229	8	
	170	66	P01646705	85	P01646717	-	220	315	200	320	229	8	
	200 F	-	-	-	-	138	P01646726	260	250	200	370	229	9
	280 F	112	P01646706	140	P01646718	-	365	350	200	370	229	9	
	300 F	-	-	-	-	207	P01646727	360	350	174	414	340	15
	495 F	198	P01646707	248	P01646719	-	595	630	174	414	340	15	
	500 F	-	-	-	-	345	P01646794	625	630	174	414	340	15
	650 F	260	P01646708	325	P01646720	-	750	900	174	414	340	15	
	780 F	-	-	-	-	538	P01646728	910	2x630	240	685	505	35
	1,000 F	400	P01646709	500	P01646721	-	1450	2x1000	240	685	505	35	
	1,400 F	-	-	-	-	966	P01646729	1900	4x700	240	685	505	35
	1,500 F	600	P01646710	750	P01646722	-	1775	4x900	240	685	505	35	
	2,000 F	-	-	-	-	1380	P01646730	3200	4x900	521	577	445	50
	2,100 F	840	P01646711	1050	P01646723	-	2600	4x1000	521	577	445	50	
2,600 F	-	-	-	-	1794	P01646731	3450	4x1400	603	577	470	62	
2,900 F	1160	P01646712	1450	P01646724	-	3400	4x1500	603	577	470	62		
2P: Three-phase, 2-phase cut-off	37	26	P01646732	32	P01646744	-	175	50	225	320	229	10	
	75	52	P01646733	65	P01646745	-	220	100	225	320	229	10	
	80	-	-	-	-	96	P01646756	225	100	325	320	229	12
	110	76	P01646734	95	P01646746	-	310	180	225	320	229	10	
	130	90	P01646735	113	P01646747	-	350	200	325	320	229	12	
	170	118	P01646736	147	P01646748	-	410	315	325	320	229	12	
	200 F	-	-	-	-	239	P01646757	485	250	325	397	229	15
	280 F	194	P01646737	242	P01646749	-	700	350	325	397	229	15	
	300 F	-	-	-	-	359	P01646758	640	350	261	414	340	22
	495 F	343	P01646738	429	P01646750	-	1150	630	261	414	340	22	
	500 F	-	-	-	-	597	P01646795	1225	630	261	414	340	22
	650 F	450	P01646739	583	P01646751	-	1465	900	261	414	340	22	
	780 F	-	-	-	-	932	P01646759	1700	2x630	410	685	505	54
	1,000 F	693	P01646740	866	P01646752	-	2865	2x1000	410	685	505	54	
	1,400 F	-	-	-	-	1673	P01646760	3750	4x700	410	685	505	54
	1,500 F	1039	P01646741	1299	P01646753	-	3510	4x900	410	685	505	54	
	2,000 F	-	-	-	-	2210	P01646761	5700	4x900	526	837	445	84
	2,100 F	1385	P01646742	1732	P01646754	-	4800	4x1000	526	837	445	84	
2,600 F	-	-	-	-	2868	P01646762	6400	4x1400	603	837	470	107	
2,900 F	1905	P01646743	2381	P01646755	-	6200	4x1500	603	837	470	107		
3P: Three-phase, 3-phase cut-off	37	26	P01646763	32	P01646775	-	330	50	300	320	229	14	
	75	52	P01646764	65	P01646776	-	400	100	300	320	229	14	
	80	-	-	-	-	96	P01646787	350	100	450	320	229	17
	110	76	P01646765	95	P01646777	-	540	180	300	320	229	14	
	130	90	P01646766	113	P01646778	-	560	200	450	320	229	17	
	170	118	P01646767	147	P01646779	-	650	315	450	320	229	17	
	200 F	-	-	-	-	239	P01646788	740	250	450	397	229	20
	280 F	194	P01646768	242	P01646780	-	1070	350	450	397	229	20	
	300 F	-	-	-	-	359	P01646789	1020	350	348	430	340	30
	495 F	343	P01646769	429	P01646781	-	1800	630	348	430	340	30	
	500 F	-	-	-	-	597	P01646796	1825	630	348	430	340	30
	650 F	450	P01646770	563	P01646782	-	2265	900	348	430	340	30	
	780 F	-	-	-	-	932	P01646790	2740	2x630	575	685	505	74
	1,000 F	693	P01646771	866	P01646783	-	4730	2x1000	575	685	505	74	
	1,400 F	-	-	-	-	1673	P01646791	5600	4x700	575	685	505	74
	1,500 F	1039	P01646772	1299	P01646784	-	5335	4x900	575	685	505	74	
	2,000 F	-	-	-	-	2210	P01646792	8000	4x900	526	1094	445	119
	2,100 F	1281	P01646773	1602	P01646785	-	6900	4x1000	526	1094	445	119	
2,600 F	-	-	-	-	2868	P01646793	9000	4x1400	603	1094	470	152	
2,900 F	1801	P01646774	2251	P01646786	-	8700	4x1500	603	1094	470	152		

(F): Model equipped with fans

Communicating with THYRITOP

All the products in the range from the **THYRITOP 20** upwards can be fitted with digital communication interfaces to communicate with the control systems on an installation, such as PCs, PLCs or supervision systems.

A large number of protocols are available:

- Profibus DPV1
- ProfiNET
- Other types
- Modbus RTU
- Modbus TCP
- on request
- DeviceNet
- EtherNet/IP

► Bus modules

for THYRITOP 20, 30 and 300

Communication is established by means of add-on bus modules mounted on a DIN rail.

Each module has a dedicated protocol and is seen as a single slave on the network with its own address. Up to 8 **THYRITOPs** from different ranges and of different types and calibres can be connected to each bus module.

In addition, they have 8 logic outputs and extra inputs for switching between the Local and Remote control modes.

Special cables are available as an option to link the modules and the **THYRITOPs**.



► Ethernet bus module

Depending on the **THYRITOP** used, it will then be possible for the control system to:

- **transmit the setpoints**
- **read the values in real time**, such as network voltage, charge voltage, current, power, status, etc.
- **access the THYRITOP parameters** to perform advanced functions.

► Communication boards

On the **THYRITOP 40** models, communication is implemented by means of an optional daughter board.

In addition to the interfaces corresponding to the protocol, they are also equipped with an auxiliary connector for simple switching between the Local and Remote control modes. Each **THYRITOP 40** is therefore seen on the network as a single slave with its own address.



► Profibus DP communication board

ACCESSORIES	THYRITOP 20	THYRITOP 30	THYRITOP 300	THYRITOP 40	REFERENCES
Profibus DP bus module	•	•	•		P01646953
Modbus RTU bus module	•	•	•		P01646952
CANopen bus module	•	•	•		P01646959
DeviceNet bus module	•	•	•		P01646960
Ethernet bus module (Profinet, Modbus TCP, Ethernet IP)	•	•	•		P01646961
4 communication bus-Thyritop cables 1.5 m long	•	•	•		P01646954
4 communication bus-Thyritop cables 2.5 m long	•	•	•		P01646955
Profibus DP communication board				•	P01646932
Modbus RTU communication board				•	P01646941
DeviceNet communication board				•	P01646942
Ethernet communication board (Profinet, Modbus TCP, Ethernet IP)				•	P01646943

Dedicated configuration and display software

► Thyrítóp-Tool

for THYRITOP 20, 30 and 40

This software, which runs in Windows, can be used to communicate the power controllers via a serial link.

It allows users to:

- **adjust the parameters** (operating modes, limits, indication)
- **command** the controller from the PC and view all the instantaneous quantities
- **display and save** measurement curves
- **record** the parameters and **compare** sets of parameters

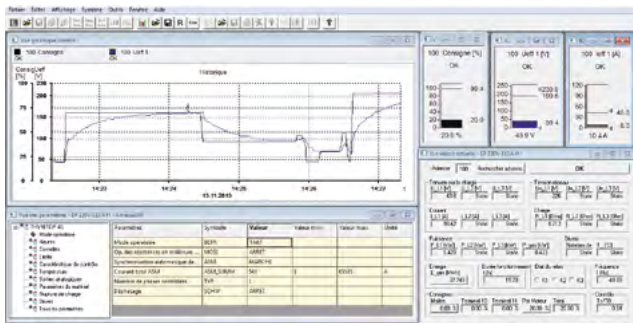

► Thyrítóp-Tool 300

for THYRITOP 300

This software can be used to **view and set the parameters of power controllers**, with intuitive navigation among the parameters, via Ethernet (RJ45) or via a specific USB cable.

With Ethernet connections, it is possible to **supervise multiple power controllers** for a better overview of the parameters.



PC- THYRITOP connection adapter

For the **THYRITOP 20** and **30**, a configuration interface has to be added to connect via RS232. On the **THYRITOP 40** the interface is built-in. An RS232 connection cable is available.

RS232 configuration interface ◀

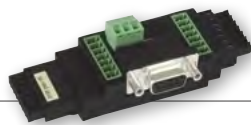

► LBA2 graphical interface: choose intuitive navigation

Interface option for simple, **intuitive navigation with the THYRITOP 40** ▶ page 13

For a remote Installation, a connection kit is available for mounting the LBA2 on the cabinet front panel.



ACCESSORIES	THYRITOP 20	THYRITOP 30	THYRITOP 300	THYRITOP 40	REFERENCES
Thyrítóp-Tool software	•	•		•	P01646931
Thyrítóp/RS232 configuration interface	•	•			P01646470
RS232 cable, DB9 M/F, length 5 m	•	•		•	P01646936
Thyrítóp-Tool 300 software			•		P01646964
USB connection cable, Thyrítóp 300/PC			•		P01646963
LBA2 graphical interface				•	P01646944
LBA2 cabinet mounting kit ([bracketing + 2.5m cable])				•	P01646935

► Optimize the load on your network with Thyritop Power Manager

When coupled with the **THYRITOP 30** or **300**, the Thyritop Power Manager can be used to optimize the overall load on your electrical network by staggering the activations of the different power control zones. It is particularly simple to implement and can be adjusted by switches and potentiometers or by software.

It can control up to 10 power controllers.

In addition to its prime function, which is synchronization, it also offers the following functions:

- **auxiliary inputs** for measuring current or voltage

- **power calculation** and energy meter
- **measurement of the network** voltage and temperature
- **configurable alarm logic outputs** (e.g. to monitor the network peak current)
- **connection possible with a bus module** for operation as an Inputs/Outputs module



Example of 6 heating zones

without synchronization

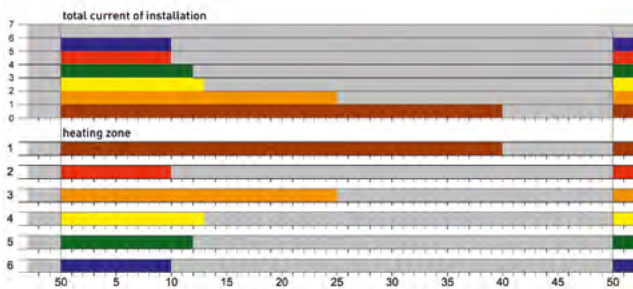

with Thyritop Power Manager synchronization

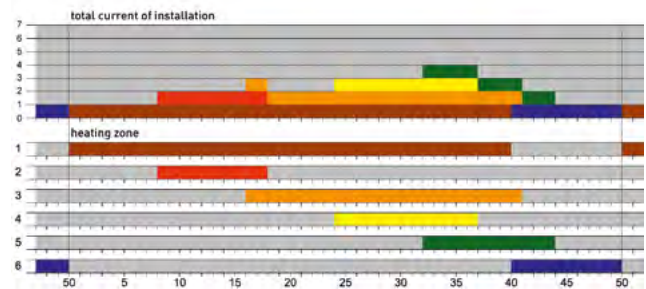

The **Power Manager** module allows users to stagger (offset) the reference periods of each power controller. In this way, zone 1 starts at T_0 , zone 2 at $T_0+T/6$, zone 3 at $T_0+2T/6$, etc. **The effect on the total current consumed is visible immediately.**

► Anti-Flicker Solution

For **THYRITOP 40**

The ASM version, developed before the dASM synchronization now supplied as standard, is still available as an option.

► DIN-rail mounting fixtures

for **THYRITOP 20** and **30**

Choice of two DIN-rail mounting fixtures depending on model: 16 A and 30 A or 45 A and 60 A.

► Power connector

for **THYRITOP 300**

For **THYRITOP 300**. Spare power connector (for 16 A and 30 A models).

ACCESSORIES	THYRITOP 20	THYRITOP 30	THYRITOP 300	THYRITOP 40	REFERENCES
Multi-zone synchronization					
Thyritop Power Manager		•	•		P01646958
ASM synchronization				•	P01646933
Mounting and connection accessories					
DIN-rail mounting fixture (for 16A and 30A models)	•	•			P01646951
DIN-rail mounting fixture (for 45A and 60A models)	•	•			P01646965
Replacement power connector (for 16A and 30A models)			•		P01646962

► Selection assistance and training

With its extensive experience, **Pyrocontrole** can help you choose the best power controller for your application in order to optimize equipment costs and performance on your installation.

We can also provide:

- **On-site commissioning services**
- **Training** in power control and use of the **THYRITOPs**
- **Dedicated technical support**

10 subsidiaries worldwide

AUSTRIA

Chauvin Arnoux Ges.m.b.H
Slamastrasse 29/2/4
1230 WIEN
Tel.: +43 1 61 61 9 61
Fax: +43 1 61 61 9 61-61
vie-office@chauvin-arnoux.at
www.chauvin-arnoux.at

CHINA

Shanghai Pu-Jiang
Enerdis Instruments Co. Ltd
3 F, 3 rd Building
N° 381 Xiang De Road
200081 SHANGHAI
Tel.: +86 21 65 21 51 96
Fax: +86 21 65 21 61 07
info@chauvin-arnoux.com.cn

GERMANY

Chauvin Arnoux GmbH
Straßburger Str. 34
77694 KEHL / RHEIN
Tel.: +49 07851 99 26-0
Fax: +49 07851 99 26-60
info@chauvin-arnoux.de
www.chauvin-arnoux.de

ITALY

AMRA SpA
Via S. Ambrogio, 23
20846 MACHERIO (MB)
Tel.: +39 039 245 75 45
Fax: +39 039 481 561
info@amra-chauvin-arnoux.it
www.chauvin-arnoux.it

MIDDLE EAST

Chauvin Arnoux Middle East
P.O. BOX 60-154
1241 2020 JAL EL DIB
(Beyrouth) - LEBANON
Tel.: +961 1 890 425
Fax: +961 1 890 424
camie@chauvin-arnoux.com
www.chauvin-arnoux.com

SPAIN

Chauvin Arnoux Ibérica SA
C/ Roger de Flor N°293
1a Planta
08025 BARCELONA
Tel.: +34 902 20 22 26
Fax: +34 93 459 14 43
comercial@chauvin-arnoux.es
www.chauvin-arnoux.es

SCANDINAVIA

CA Mätssystem AB
Box 4501
SE 18304 Täby
Tel.: +46 8 50 52 68 00
Fax: +46 8 50 52 68 10
info@camatsystem.com
www.camatsystem.com

SWITZERLAND

Chauvin Arnoux AG
Moosacherstrasse 15
8804 AU / ZH
Tel.: +41 44 727 75 55
Fax: +41 44 727 75 56
info@chauvin-arnoux.ch
www.chauvin-arnoux.ch

UNITED KINGDOM

Chauvin Arnoux Ltd
Unit 1 Nelson Ct, Flagship Sq
Shaw Cross Business Pk, Dewsbury
West Yorkshire - WF12 7TH
Tel.: +44 1924 460 494
Fax: +44 1924 455 328
info@chauvin-arnoux.co.uk
www.chauvin-arnoux.com

USA

Chauvin Arnoux Inc
d.b.a AEMC Instruments
200 Foxborough Blvd.
Foxborough - MA 02035
Tel.: +1 (508) 698-2115
Fax: +1 (508) 698-2118
sales@aemc.com
www.aemc.com

Contact us:

PYROCONTROLE
6 bis avenue du Docteur Schweitzer
69881 MEYZIEU Cedex
FRANCE

info@pyro-controlle.tm.fr

 +33 4 72 14 15 40

Check out PYROCONTROLE at www.pyrocontrolle.com

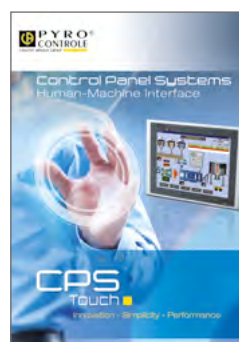

Request our other
product catalogues

 **PYRO**[®]
CONTROLE
CHAUVIN ARNOUX GROUP