

TEMPERATURE SENSORS

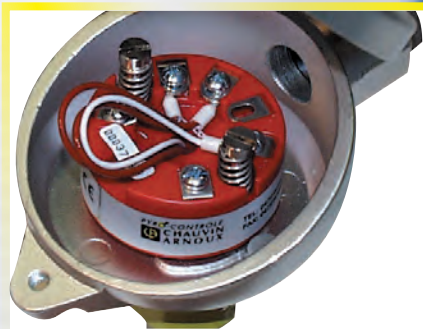
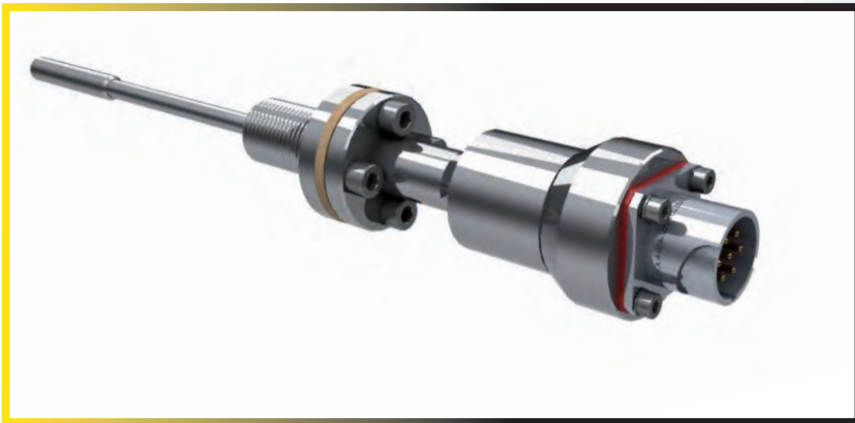

PYRO-CONTRÔLE, a leading French provider of temperature sensors for industrial use, joined Chauvin Arnoux in 1997, affording it access to the Group's six Research & Development centres, as well as an international sales network handled by ten subsidiaries in Europe, the United States and China.

Located near Lyon, in the south of France, **the PYRO-CONTRÔLE industrial site designs, manufactures and markets temperature sensors and industrial temperature measurement and control systems.**

From tailor-made to production line products, **PYRO-CONTRÔLE** can adapt to the specific requirements of each customer, and is able to cater for all temperature measurement needs thanks to its **mastery of the entire temperature process loop.**

The company's scope of intervention covers demanding process industries, such as the chemical, petrochemical, glass, ceramics, metallurgy and nuclear sectors.

PYRO-CONTRÔLE received version 2000 ISO 9001 certification for its entire quality system and also has COFRAC n° 2-1385 accreditation for temperature metrology from -20 °C to +1,550 °C.

The **CHAUVIN ARNOUX GROUP** is a European market leader in the measurement sector and proposes a comprehensive product offering with its three companies: **PYRO-CONTRÔLE**, **ENERDIS** and **CHAUVIN ARNOUX Test & Measurement**. It also provides a services offering with the **MANUMESURE** company.

Find out more at: www.chauvin-arnoux.com

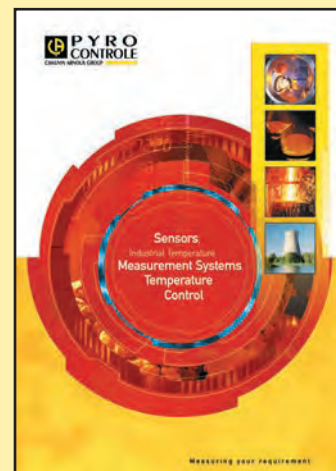

In this catalogue

▶ **Define your sensor in as little as 2 or 3 stages.**

3 criteria:

- Type of output (head, connector, cable)
- Type of sensing element (RTD 100 Ω, TC J, TC K)
- Temperature resistance

or: Type of application

or: Components, replacements and accessories

▶ **1,200 standard temperature sensor references**

▶ **Fast delivery**

For any other requirements, consult our product listing at: www.pyro-controle.com



▶ **Specialised temperature sensors per application**

For each application, a complete offer of specialised sensor:
chemicals - glass - metallurgy - plastics - agri-food - pharmacy - etc.



▶ **Customised temperature sensors**

Define your requirements and contact us

Technical reminders and how to choose	4
Glossary	p. 4
Defining your temperature sensor	p. 6
Applicable Standards and Directives	p. 8
RTD 100 Ω technology	p. 9
Thermocouple technology	p. 11
Connection head output sensors, without G1/2 fitting	13
RTD 100 Ω sensors, 200 °C resistant	p. 13
RTD 100 Ω sensors, 450 °C resistant	p. 14
J type sheathed thermocouples	p. 15
K type sheathed thermocouples	p. 16
Connection head output sensors, with G1/2 fitting	17
RTD 100 Ω sensors, 200 °C resistant	p. 17
RTD 100 Ω sensors, 450 °C resistant	p. 18
J type sheathed thermocouples	p. 19
K type sheathed thermocouples	p. 20
Cable output sensors	21
RTD 100 Ω sensors, 200 °C resistant	p. 21
RTD 100 Ω sensors, 450 °C resistant	p. 22
J type sheathed thermocouples, PVC cable	p. 23
J type sheathed thermocouples, FEP cable	p. 24
K type sheathed thermocouples, PVC cable	p. 25
K type sheathed thermocouples, FEP cable	p. 26
Connector output sensors	27
RTD 100 Ω sensors, 200 °C resistant	p. 27
RTD 100 Ω sensors, 450 °C resistant	p. 28
J type sheathed thermocouples, miniature male connector	p. 29
J type sheathed thermocouples, standard male connector	p. 30
K type sheathed thermocouples, miniature male connector	p. 31
K type sheathed thermocouples, standard male connector	p. 32
Extension cables	p. 33
Beaded thermocouple assemblies	34
J type beaded thermocouples	p. 34
K type beaded thermocouples	p. 35
S type beaded thermocouples, 600 °C –1,200 °C resistant	p. 36
S type beaded thermocouples, maximum temperature 1,600 °C	p. 37
Sensors for applications	38
Ambient temperature sensors	p. 38
Surface sensors	p. 39
Sensors for the aluminium industry	p. 40
Sensors for the plastics industry	p. 41
Replacement thermocouples	42
Sheathed K and J thermocouples, naked wire output	p. 42
K and J thermocouples, naked, straight, welded	p. 43
K and J thermocouples, beaded, welded	p. 44
K and J thermocouple wires, fiberglass insulated, welded	p. 45
Portable thermometers	46
RTD 100 Ω sensors	p. 46
Infrared	p. 46
K Thermocouple	p. 47
Accessories for temperature sensors	48
Accessories for electrical connection	p. 48
Sensing elements with platinum resistance	p. 51
Wires and cables	p. 52
Protection components	p. 55
Connection components	p. 59
Transmitters	p. 61

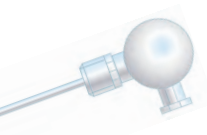

Technical terms used in temperature metrology

Cold junction (reference junction):

Junction whose known temperature is used as measuring reference (theoretically at 0 °C, measured practically).

Compensation cable:

Cable consisting of conductors that are different to those of the thermoelectric couple, but with similar thermoelectric specifications, so as to render errors resulting from its use negligible for a given temperature range.

By convention, the temperature to which the junctions and elements of the thermoelectric couple/compensation conductor are exposed is limited to 200 °C, so as to ensure that the electromotive force developed in the two compensation conductors is equal to that developed by the thermoelectric couple at the same temperature.

Consistency of a sensor:

Quality characterising the aptitude of a sensor, for a given value of the quantity to be measured, to provide readings that are consistent, without taking systematic errors into consideration.

Extension cable:

Cable consisting of conductors of the same nature as the elements of the thermoelectric couple and which extends this to the thermocouple's reference junction.

Hot junction (measurement junction):

Junction placed at point at which the temperature is to be measured.

Insulated thermoelectric couple:

Thermoelectric couple whose elements are electrically insulated from one another elsewhere than at their junction.

Insulation resistance:

Electrical resistance between the sensing element and adjoining conductive parts, be they part of the sensor itself or of its environment. Its value depends on the conditions of use, and in particular on the temperature.

Interchangeability of sensor:

Quality characterising the aptitude of a sensor to replace another sensor, without altering the performances of a measuring device.

International temperature scale (ITS):

We differentiate between:

- the International Practical Kelvin Temperature: T_{90} .

Unit: Kelvin, symbol: K.

and

- the International Practical Celsius Temperature t_{90} .

Unit: degree Celsius, symbol: °C.

Both temperatures being linked by the expression:

$$t_{90} = T_{90} - 273,16K$$

The **Kelvin** is equal to 1/273.16 of the thermodynamic temperature of the triple point of water.

The ITS 90 is based on the temperature values assigned to a certain number of reproducible states of equilibrium (fixed points) and for specified instruments calibrated at these temperatures.

Interpolation between the temperatures of the fixed points is calculated using formulae that define the relationship

between the readings of these instruments and the values of the International Temperature Scale.

Joule effect:

All conductors through which a current passes are subject to heating known as the Joule effect.

Measurement line:

The measurement of a physical quantity implies not only the use of a sensor, but also a measuring instrument.

The measurement line is the line of transducing elements and linking devices of the measuring instrument placed between the sensor - first element of the line - and the indicator device, which is the last element of the line (see measurement transducer).

Measurement range:

Algebraic difference between the extreme values read for the quantity to be measured and for which the metrological specifications of the sensor defined elsewhere are guaranteed. The unit is that of the quantity to be measured.

Reference table:

Table for linking the sensor output reading to the value of the quantity to be measured.

With the reference junction of a couple being maintained at 0 °C, the electromotive force it delivers when its measurement junction is brought to a temperature t is specific to the couple and the temperature.

For each type of thermoelectric couple, E.M.F./temperature reference tables are established which enable the temperature t to be deduced from the E.M.F. measured and vice versa.

Repeatability:

For each value of the quantity to be measured, there exist two sensor reading values depending on whether the value has been obtained by a rising or falling variation.

The repeatability rating is equal to the maximum difference observed between these two values for a given measurement range.

Resistance/temperature variation law:

The fundamental values of platinum measurement resistances for the measurement ranges 0 to 850 °C and -200 °C to 0 °C are determined on the basis of the following interpolation functions: (Values based on ITS 90.):

$$R(t) - R_0 (1 + At + Bt^2) \quad \text{from } 0^\circ\text{C to } 850^\circ\text{C}$$

$$R(t) = R_0 [1 + At + Bt^2 + Ct^3 (t-100)] \quad \text{from } -200^\circ\text{C to } +0^\circ\text{C}$$

$$A = 3.9083 \times 10^{-3} \text{ } ^\circ\text{C}^{-1}$$

$$B = -5.775 \times 10^{-7} \text{ } ^\circ\text{C}^{-2}$$

$$C = -4.183 \times 10^{-12} \text{ } ^\circ\text{C}^{-3}$$

Resistivity:

At constant temperature, the resistivity of a metal conductor of given length and cross-section is a characteristic of the material itself and depends on its nature. It is expressed in ohm-m.

$$\rho = R \times S / L$$

$$\rho = \text{resistivity of material } (\Omega \cdot \text{m})$$

$$R = \text{resistivity measured } (\Omega)$$

$$S = \text{cross-section of conductor } (\text{m}^2)$$

$$L = \text{length of conductor } (\text{m})$$

Resolution:

The smallest perceptible variation in the information provided by a measuring instrument in reference conditions. For a resistance thermometer, the resolution is the limit towards which the ratio ΔR tends when Δt tends towards 0.

Seebeck effect (or Thermoelectric effect):

The Seebeck effect is the phenomenon resulting from the production of an electrical current in a circuit composed of two conductors of different natures whose junctions are placed at two different temperatures.

Self-heating:

Self-heating of temperature sensor due to current passing through it. Depends on conditions in which sensor is used, especially the specifications of its immediate environment. Measured in degrees per Watt: $^{\circ}\text{C}\cdot\text{W}^{-1}$.

Self-heating coefficient:

The intensity I of a current passing through a sensing element of resistance R . The power produced by the Joule effect ($P = R \cdot I^2$) raises the temperature of the sensor by Δt ; The self-heating coefficient is defined by:

$$K = \Delta t / P$$

K is expressed in degrees per Watt: $^{\circ}\text{C}\cdot\text{W}^{-1}$

Sensitivity:

For a given value of the quantity measured, the sensitivity is expressed by the quotient of the variable increase observed by the corresponding increase for the value measured.

Example:

For a resistance thermometer: $\Delta R / \Delta t$

For a thermoelectric couple: $\Delta E / \Delta t$

Sensor:

Element of measuring instrument used for registering data relating to the quantity to be measured, consisting of a test body (if there is one) and a sensing element.

Sensor response deviation:

For a given value of the quantity to be measured, the response deviation is the difference between the sensor output reading and the standard true value given in the reference table by a recognised standard or theoretical law.

Sheathed thermoelectric couple:

Thermoelectric couple immersed in an isolating mineral and compacted inside a metal sheath that is both pliable and watertight.

Temperature coefficient:

Average value of variation in resistance between 0 and 100 $^{\circ}\text{C}$, given by the following:

$$\alpha_{100} = (R_{100} - R_0) / 100 \times R_0$$

R_0 and R_{100} being respectively the values of the resistance at 0 and at 100 $^{\circ}\text{C}$, α is expressed in $^{\circ}\text{C}^{-1}$

Temperature:

By uniting two identical bodies at the same temperature, a new body is obtained whose mass and volume have doubled, but whose temperature remains unchanged. While it is possible, therefore, to define the equality of two temperatures, it is impossible to define their addition.

Temperature strictly speaking therefore cannot be measured, but only read according to an established system.

In thermodynamic terms, it is possible to specify what the quantity "temperature" represents by defining it according to the Carnot principle.

Under such conditions, the thermodynamic "temperature" is expressed with respect to a unit of the property considered and not, as is usually the case, with respect to a scale.

Thermal conduction:

Conduction occurs when materials—especially solids—are in direct contact with each other. Heat conduction is the transfer of energy (heat transfer) from more energetic to less energetic particles due to some form of interaction between these particles.

Thermal convection:

Convection is transfer of heat when a fluid is in motion. Convection involves a transfer of thermal energy by microscopic particle-particle interaction and bulk motion of the fluid, for which the particles are all moving together.

Thermal insulation:

Normally, heat is transferred by from one material to another by conduction, convection and/or radiation. Insulators are used to minimize that transfer of heat energy.

Thermoelectric couple:

Unit consisting of two homogeneous conductors of different natures, joined at their extremities and developing an electromotive force by the Seebeck effect, dependent on the temperatures of their junctions.

In practice, a thermoelectric couple is composed of two conductive elements joined at one of their extremities, with the other extremity connected to a measuring instrument.

Thermometric/pyrometer assembly:

Unit composed of the sensing element (thermometric element, thermoelectric couple), its electrical insulation and (where this exists) protective casing.

A thermometric rod is equipped with electrical connection devices (connectors, wiring, terminals, etc.) and mechanical fittings.

Time constant of a sensor:

The response of a sensor to a given temperature interval corresponds more often than not to an exponential distribution with the form:

$$S(t) = S_1 + (S_2 - S_1)(1 - \exp(-t/\tau))$$

$S(t)$ sensor output temperature reading

S_1 sensor output reading corresponding to the initial temperature value

S_2 sensor output reading corresponding to the final temperature value

τ time constant

The time constant is the response time at 63 %, where the reaction time of the sensor is considered negligible.

Radiation transfer:

Hot and even warm objects radiate infrared electromagnetic waves, which can heat up objects at a distance, as well as lose energy themselves. The use of reflective materials usually provides insulation against heat transfer by radiation.

Deciding factors when choosing a temperature sensor

Number of sensing elements

Simple or duplex: simple in the case of a single sensing element, duplex when two sensing elements are necessary, e.g. for redundancy (measurement reliability) or different uses (one for measuring, one for display).

Temperature ranges

Type of resistance		Temperature range	Atmosphere
RTD 100 Ω		-200 / +600 °C	Average oxidising
Type of thermocouple	Code	Temperature range	Atmosphere
Cu – CuNi	T	-20 / +350 °C	Average oxidising or reducing
Fe – CuNi	J	-20 / +760 °C	Reducing, limited use in oxidising atm.
NiCr - Ni alloy	K	-40 / +1,100 °C	Clean oxidising and inert
Nicrosil – Nisil	N	0 / 1,100 °C	Clean oxidising, limited use in reducing atm.
Pt - PtRh 13 %	R	0 / 1,600 °C	Oxidising
Pt - PtRh 10 %	S	0 / 1,550 °C	Oxidising
PtRh 6 % - PtRh 30 %	B	100 / 1,600 °C	Oxidising
Tungsten(W) Rhenium (Re)	W/Re	0 / 2,300 °C	Reducing, inert, hydrogenous

In theory, **RTD 100 Ωs** withstand temperatures of up to 600 °C, but for commonly-used sensors, **450 °C is the recommended upper limit.**

The performance of sheathed thermocouples is directly related to their diameter, in relation to the temperature at which they are used.

Maximum operating temperatures for sheathed thermocouples:

Ø TCG	J, stainless steel sheathed	K, inconel 600 sheathed
0.5 mm	250 °C	350 °C
1 mm	300 °C	400 °C
2 mm	300 °C	500 °C
3 mm	450 °C	750 °C
4.5 mm	450 °C	1000 °C
6 mm	600 °C	1100 °C
8 mm	600 °C	1100 °C

These maximum operating temperatures are for information purposes. Operating conditions (oxidising or reducing atmosphere, thermal cycling, etc.) can alter these characteristics.

Particular attention should be paid to drift, which is sometimes quite high for thermocouples (pollution and metallurgical diffusion at the hot spot).

Regular calibration may be appropriate.

Accuracy range

Type of sensing element: see interchangeability tolerance levels in the following chapters, devoted to RTD 100 Ω and thermocouples.

For cable output thermocouples, see extension and compensation cable tolerance levels table in the following chapter devoted to thermocouples.

Calibration: for desired accuracy lower than interchangeability level, it necessary to carry out a calibration that enables (allowing for uncertainty) the actual difference between the measurement indicated by the sensor and the actual temperature to be defined.

Dimensions

Naturally, external dimensions must not be overlooked: length and diameter.

Electrical connection

Electrical connection is achieved using a head (connection to a terminal block or a transmitter), a connector or a cable. For RTD 100 Ω s: see connection table in the following chapter devoted to RTD 100 Ω s.

For thermocouples: see connection table in the following chapter devoted to thermocouples.

Heads, connectors and cables have upper operational temperature limits depending on the materials used:

MA Type connection head:	100 °C	Thermocouple connectors:	220 °C (*)
PM Type connection head:	150 °C (*)	PVC sheathed cable or wires:	100 °C
Din B Type connection head:	100 °C	Silicone, FEP or PTFE sheathed cable or wires:	200 °C (*)
Connection head with transmitter (DAN type):	85 °C	Fiberglass sheathed cable or wires:	250 °C (*)
RTD 100 Ω connectors:	100 °C		

(*): in practice, it is advisable never to exceed 100 °C to accommodate insulation components that may be used in the connection, such as araldite glue.

Dynamics of the process

The response time must correspond to the dynamics of the process and the ultimate use of the measurement.

The principle of measuring response times is described in the IEC 751 standard.

63 % response time of standard TCG sensors depending on diameter:

Diameter	0.5 mm	1 mm	1.5 mm	2 mm	3 mm	4.5 mm	6 mm	8 mm
TCG J or K*	0.3 s	0.4 s	0.6 s	0.9 s	1.5 s	2 s	4 s	7 s

(*) with isolated hot welding

Abrasion, corrosion and pressure

The protective materials must be adapted to suit operating conditions, especially abrasion and corrosion.

For pressure vessels, the definition rules must include compliance with the PED Directive (see following page).

Vibrations

The construction around the sensing element must be particularly robust in the likelihood of severe vibration conditions.

Connection to process

Plan what you will use to attach the sensor to the process: flange, connector, adjustable compression fitting, etc.

The resistance of adjustable compression fittings to pressure depends on several factors: material comprising the ferrule is, diameter and temperature, and type of protection (tube or sheathed cable).

The table below displays the characteristic of maximum operating pressure values.

Type of adjustable compression fitting	Type of ferrule	Type of sensor	Operating temperature	Ø 3 mm	Ø 4.5 mm	Ø 6 mm	Ø 8 mm
Stainless steel	Stainless steel	RTD100	20 °C	300 bar	400 bar	300 bar	400 bar
			450 °C	170 bar	220 bar	170 bar	220 bar
Stainless steel	Stainless steel	TCG	20 °C	500 bar	500 bar	500 bar	500 bar
			450 °C	250 bar	250 bar	250 bar	250 bar
Stainless steel	PTFE	RTD100 and TCG	20 °C	5 bar	5 bar	5 bar	5 bar

Communication

Format of the output quantity (analogue, digital, communication protocol).

In the case of digital or analogue outputs, transmitter at connection head.

Environment

Compliance with applicable European Standards and Directives. See table on the following page.

Applicable European Directives

The **ATEX 94/9/CE Directive** applies to equipment in explosive atmospheres.

Temperature measurements in explosive zones are subject to this directive.

Our Production Quality Assurance Notification is certified by INERIS (French National Institute for Industrial Environment and Risks) under the no. **INERIS 03 ATEX Q402**.

Our **NT96-03** documentation presents the consequences of the application of this directive for our measuring instruments.

The **97/23/CE Pressure Equipment Directive** applies to pressurised equipment and so, naturally, to temperature sensor protectors such as bored wells, which are part of the envelope.

However, sensors do not come under the Pressure Equipment Directive.

Our **NT96-02** documentation presents the consequences of the application of this directive for our measuring instruments.

The **CEM 89/336 Directive** applies to electrical or electronic equipment that can transmit or be disturbed by electromagnetic waves.

Our in-head transmitters comply with **Emissions** standard **EN50 081-1** and **Receivers** standard **EN50 082-2**.

Applicable Standards

Electrical material for explosive atmospheres

EN 50014	General Rules
EN 50015	Immersion in oil
EN 50016	Internal overpressure
EN 50017	Pulverulent filling
EN 50018	Explosion proof envelope
EN 50019	Increased safety "e"
EN 50020	Intrinsic safety "i"

Metrological vocabulary

IEC 60050-300	International vocabulary of fundamental and general metrological terms
---------------	--

Thermoelectric couples

IEC 584-1 (ex NFC 42-321)	Tables of reference
IEC 584-2 (ex NFC 42-322)	Tolerances
IEC 584-3 (ex NFC 42-323)	Identification of thermoelectric couples and compensation cables.
IEC 584-4 (ex NFC 42-324)	Extension and compensation cables for thermoelectric couples. Composition, nature of materials, production tests.
IEC 584-5 (ex NFC 42-325)	"Sheathed" cables and thermocouples.

Platinum resistance thermometers

IEC 751 (ex NFC 42-330)	Table of references and tolerances
-------------------------	------------------------------------

Materials

NF EN 10088-1	Codification of European stainless steel standards
NF A 35 610	Equivalence table of French and foreign steel variants.

RTD 100 Ω Sensors

The relationship between resistance and temperature, and the corresponding tolerances, are defined by European standards IEC 751.

We distinguish two technology types:

- **platinum resistance thermometers with platinum wire wound on an insulating support.** The latter is usually ceramic but can sometimes be glass. Operating temperatures range up to 450 °C, and in exceptional cases up to 850 °C. These sensing elements provide higher accuracy and greater stability.
- **platinum coating on a ceramic base.** Operating temperatures range up to 450 °C. Although these are less stable than conventional winding elements, they provide greater resistance to vibrations up to 200 °C, a shorter response time and a lower cost.

Other materials have characteristic temperature laws: Copper and Nickel (less and less frequently used).

IEC 751 reference table (excerpts): temperature and resistance

$^{\circ}\text{C}$ ITS 90	Ω	$^{\circ}\text{C}$ ITS 90	Ω	$^{\circ}\text{C}$ ITS 90	Ω	$^{\circ}\text{C}$ ITS 90	Ω	$^{\circ}\text{C}$ ITS 90	Ω
-200	18.52	10	103.90	210	179.53	410	250.53	610	316.92
-190	22.83	20	107.79	220	183.19	420	253.96	620	320.12
-180	27.10	30	111.67	230	186.84	430	257.38	630	323.30
-170	31.34	40	115.54	240	190.47	440	260.78	640	326.48
-160	35.54	50	119.40	250	194.10	450	264.18	650	329.64
-150	39.72	60	123.24	260	197.71	460	267.56	660	332.79
-140	43.88	70	127.08	270	201.31	470	270.93	670	335.93
-130	48.00	80	130.90	280	204.90	480	274.29	680	339.06
-120	52.11	90	134.71	290	208.48	490	277.64	690	342.18
-110	56.19	100	138.51	300	212.05	500	280.98	700	345.28
-100	60.26	110	142.29	310	215.61	510	284.30	710	348.38
-90	64.30	120	146.07	320	219.15	520	287.62	720	351.46
-80	68.33	130	149.83	330	222.68	530	290.92	730	354.53
-70	72.33	140	153.58	340	226.21	540	294.21	740	357.59
-60	76.33	150	157.33	350	229.72	550	297.49	750	360.64
-50	80.31	160	161.05	360	233.21	560	300.75	760	363.67
-40	84.27	170	164.77	370	236.70	570	304.01	770	366.70
-30	88.22	180	168.48	380	240.18	580	307.25	780	369.71
-20	92.16	190	172.17	390	243.64	590	310.49	790	372.71
-10	96.09	200	175.86	400	247.09	600	313.71	800	375.70
0	100.00							810	378.68
								820	381.65
								830	384.60
								840	387.55
								850	390.48

Tolerance class

The standard IEC 751 defines interchangeability tolerances as follows:

Tolerance class	Tolerance
A	$0.15 + 0.002 \times [t]$
B	$0.3 + 0.005 \times [t]$

where [t] is the absolute value of the temperature in $^{\circ}\text{C}$

According to this standard, the tolerance class A cannot be applied to thermometers exposed to temperatures exceeding 650 $^{\circ}\text{C}$.

According to our experience, we recommend limiting RTD 100 Ω industrial sensors to 450 $^{\circ}\text{C}$ for Class A tolerance.

RTD 100 Ω Sensors

Tolerance classes for RTD 100 Ω :

Temperature (°C)	Tolerance			
	Class A		Class B	
	(+/- °C)	(+/- Ω)	(+/- °C)	(+/- Ω)
-200	0.55	0.24	1.30	0.56
-100	0.35	0.14	0.80	0.32
0	0.15	0.06	0.30	0.12
100	0.35	0.13	0.80	0.30
200	0.55	0.20	1.30	0.48
300	0.75	0.27	1.80	0.64
400	0.95	0.33	2.30	0.79
500	1.15	0.38	2.80	0.93
600	1.35	0.43	3.30	1.06
650	1.45	0.46	3.60	1.13

Class A/2: tolerance at 0 °C is divided by 2. Curve parallel to Class A. Tolerance: $0.075 + 0.002 \times t$

Class A/5: tolerance at 0 °C is divided by 5. Curve parallel to Class A. Tolerance: $0.003 + 0.002 \times t$

Electrical connection

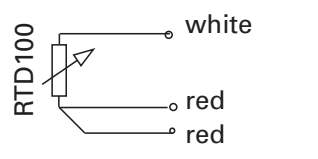
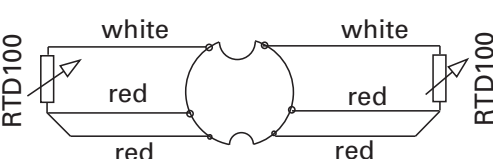
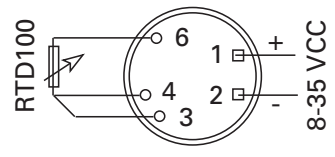

RTD 100 Ω CONNECTION USING DIN TYPE CONNECTION HEADS

<p>1 RTD100 - 1 x 3 wires</p> 	<p>2 RTD100 - 2 x 3 wires</p> 	<p>CONNECTION PR type transmitter 1RTD100 - 1 x 3 wires</p> 
---	--	---

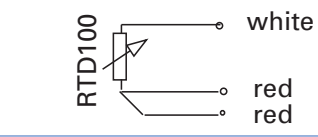
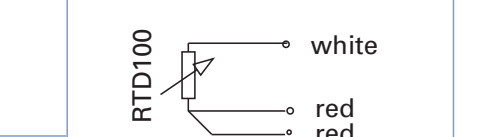
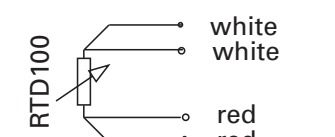
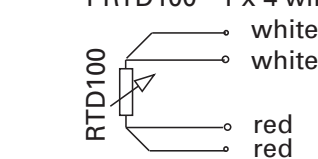
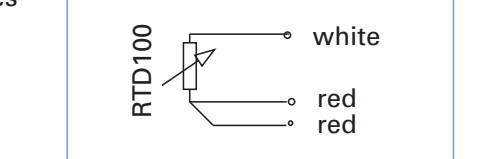
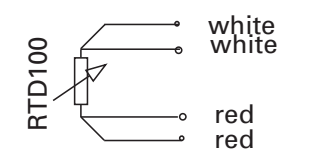
RTD 100 Ω CONNECTION USING CABLES

<p>1 RTD100 - 1 x 3 wires</p> 	<p>2 RTD100 - 2 x 3 wires</p> 	<p>2 RTD100 - 2 x 4 wires</p> 
<p>1 RTD100 - 1 x 4 wires</p> 	<p>2 RTD100 - 2 x 3 wires</p> 	<p>2 RTD100 - 2 x 4 wires</p> 

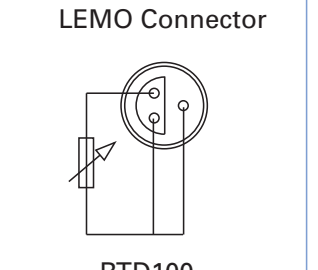
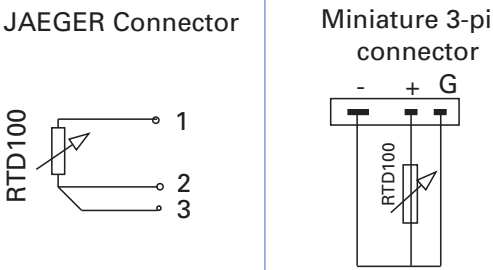
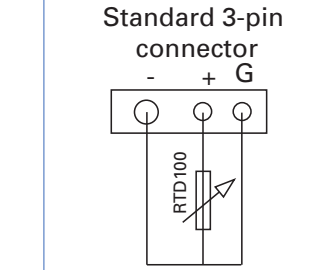
RTD 100 Ω CONNECTION USING CONNECTORS - 1 x 3 wires connection

<p>LEMO Connector</p>  <p style="text-align: center;">RTD100</p>	<p>JAEGER Connector</p> 	<p>Miniature 3-pin connector</p> 	<p>Standard 3-pin connector</p> 
---	--	--	---

Thermocouple sensors

The sensor consists of two wires welded at the hot junction of the thermoelectric couple; readings are made at the cold junction, which must be compensated to simulate 0 °C. Various materials are used to make the thermocouples.

Thermoelectric force and tolerances are determined in compliance with the IEC 584 standard.

IEC 584 Reference Tables (excerpts): temperature and voltage in mV

Temperature	Type of thermocouple							ASTM E988 WRe 3% -25%
	IEC 584							
	T	J	K	N	R	S	B	
-40 °C	-1.475	-1.960	-1.527	-1.023	-0.188	-0.194		
0 °C	0	0	0	0	0	0	0	0
50 °C	2.036	2.585	2.023	1.340	0.296	0.299	0.002	0.528
100 °C	4.279	5.269	4.096	2.774	0.647	0.646	0.033	1.145
150 °C	6.704	8.010	6.138	4.302	1.041	1.029	0.092	1.841
200 °C	9.288	10.779	8.138	5.913	1.469	1.441	0.178	2.603
300 °C	14.862	16.327	12.209	9.341	2.401	2.323	0.431	4.287
400 °C	20.872	21.848	16.397	12.974	3.408	3.259	0.787	6.130
500 °C		27.393	20.644	16.748	4.471	4.233	1.242	8.078
600 °C		33.102	24.905	20.613	5.583	5.239	1.792	10.088
800 °C			33.275	28.455	7.980	7.345	3.154	14.170
1000 °C			41.276	36.256	10.506	9.587	4.834	18.230
1200 °C			48.838	43.846	13.228	11.951	6.786	22.149
1400 °C					16.040	14.373	8.956	25.882
1600 °C					18.843	16.777	11.263	29.412
1800 °C							13.591	32.712
2000 °C								35.717

Interchangeability tolerance class in compliance with standard NF EN 60584-2

Type	Class 1	Class 2
T	from -40 to +125°C ± 0.5°C from 125 to 350 °C ± 0.004 x t °C	from -40 to +133°C ± 1°C from 133 to 350 °C ± 0.0075 x t °C
J	from -40 to +375°C ± 1.5°C from 375 to 750 °C ± 0.004 x t °C	from -40 to +333°C ± 2.5°C from 333 to 750 °C ± 0.0075 x t °C
K	from -40 to +375°C ± 1.5°C from 375 to 1000 °C ± 0.004 x t °C	from -40 to +333°C ± 2.5°C from 333 to 1200 °C ± 0.0075 x t °C
N	from -40 to +375°C ± 1.5°C from +375 to +1000 °C ± 0.004 x t °C	from -40 to +333°C ± 2.5°C from 333 to 1200 °C ± 0.0075 x t °C
R – S	from 0 to +1100 °C ± 1°C	from 0 to +600 °C ± 1.5°C
B	from 1100 to 1600 °C ± (1+0.003x(t-1100)) °C	from +600 to +1600 °C ± 0.0025 x t °C
		from +600 to +1700 °C ± 0.0025 x t °C

"t" is the temperature in °C

Extension and compensation cables

Colour codes

T.C Symbol	Extension symbol	Compensation symbol	NFC 42323 Feb. 1985	IEC 584-3 Jul. 90 NFC 42324 Dec. 93
T	TX	TC		
J	JX	JC		
E	EX	EC		
K	KX	KC		
N	NX	NC		
R-S		KC / SCA		
B		BC		

Tolerance Class

Type of TC	Tolerance class		Temperature range of cable	Temperature of measurement junction
	1	2		
JX	+/- 1.5 °C	+/- 2.5 °C	-25 °C to +200 °C	300 °C
TX	+/- 0.5 °C	+/- 1.0 °C	-25 °C to +100 °C	500 °C
EX	+/- 1.5 °C	+/- 2.5 °C	-25 °C to +200 °C	900 °C
KX	+/- 1.5 °C	+/- 2.5 °C	-25 °C to +200 °C	900 °C
NX	+/- 1.5 °C	+/- 2.5 °C	-25 °C to +200 °C	900 °C
KCA		+/- 2.5 °C	0 °C to +150 °C	900 °C
KCB		+/- 2.5 °C	0 °C to +100 °C	900 °C
NC		+/- 2.5 °C	0 °C to +150 °C	1000 °C
RCA		+/- 2.5 °C	0 °C to +100 °C	1000 °C
RCB		+/- 5.0 °C	0 °C to +200 °C	1000 °C
SCA		+/- 2.5 °C	0 °C to +100 °C	1000 °C
SCB		+/- 5.0 °C	0 °C to +200 °C	

Note: A cable made up of two copper conductors can be used with B type thermocouples.
The maximum extra deviation possible for the cable temperature range between 0 °C and 100 °C is 40 µV.
The equivalent temperature difference is 3.5 °C, when the temperature of the thermocouple junction is 1,400 °C.

Electrical connection of thermocouple sensors

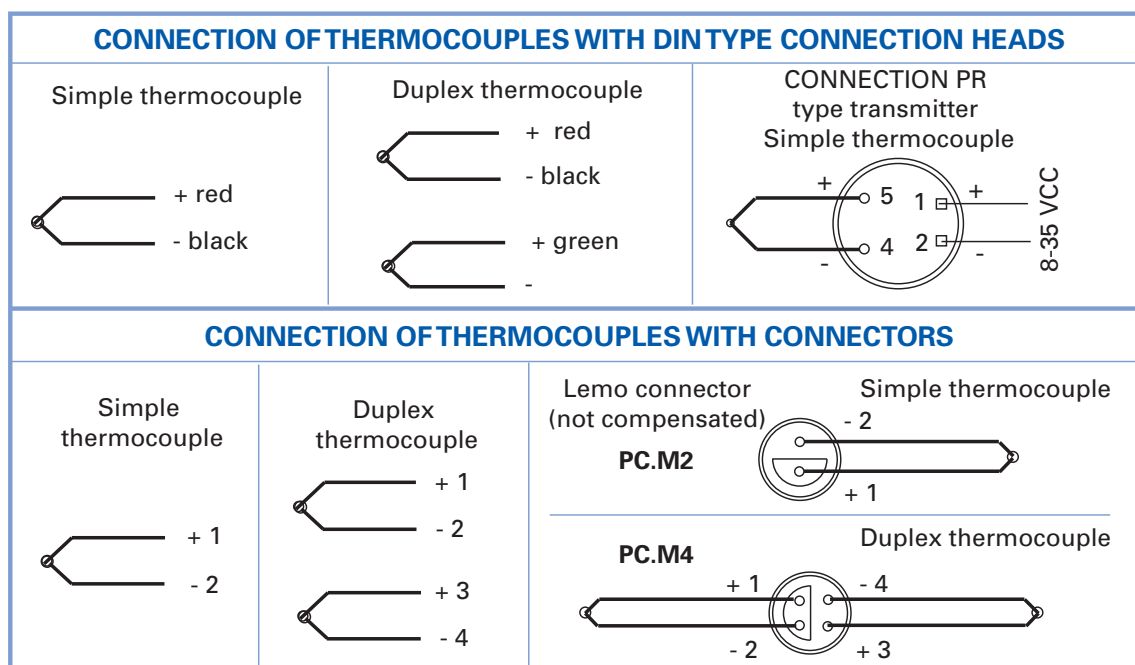

Description:

- RTD 100 Ω probe, class A, complies with NF EN 60751 standard
available in: simple or duplex
- 316L stainless steel protective sheathing, 6 mm diameter
available in: L1 length
- DIN format head connection, IP54 protection
available in: MA, PM, DIN B or DAN
 - Electrical connection to terminal block: MA, PM and DIN B
 - Connection to linearised 4-20 mA output transmitter: DAN
 - PE9, PE11 or PE16 cable gland, depending on model (see p. 48)

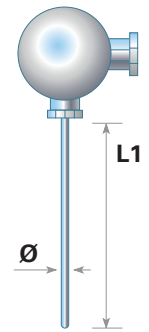

Models and codes for ordering



Probe Qty	Wiring	L1 (mm)	Ø (mm)	S51-200 MA terminal block head	S50-200 PM terminal block head	S53-200 DIN B terminal block head	S52-200 DAN head transmitter*	
1 x 100 Ω	1 x 3 wires	50	6	L305114-003	L305014-003	L305314-003	L305214-103	
		100		L305114-006	L305014-006	L305314-006	L305214-106	
		150		L305114-007	L305014-007	L305314-007	L305214-107	
		200		L305114-008	L305014-008	L305314-008	L305214-108	
		300		L305114-010	L305014-010	L305314-010	L305214-110	
		500		L305114-014	L305014-014	L305314-014	L305214-114	
2 x 100 Ω	2 x 2 wires	200		L305134-008	L305034-008			
		300		L305134-010	L305034-010			
		500		L305134-014	L305034-014			
	2 x 3 wires	200					L305344-008	
		300					L305344-010	
		500				L305344-014		

*Sensors with transmitters: indicate the temperature range, default 0-150 °C

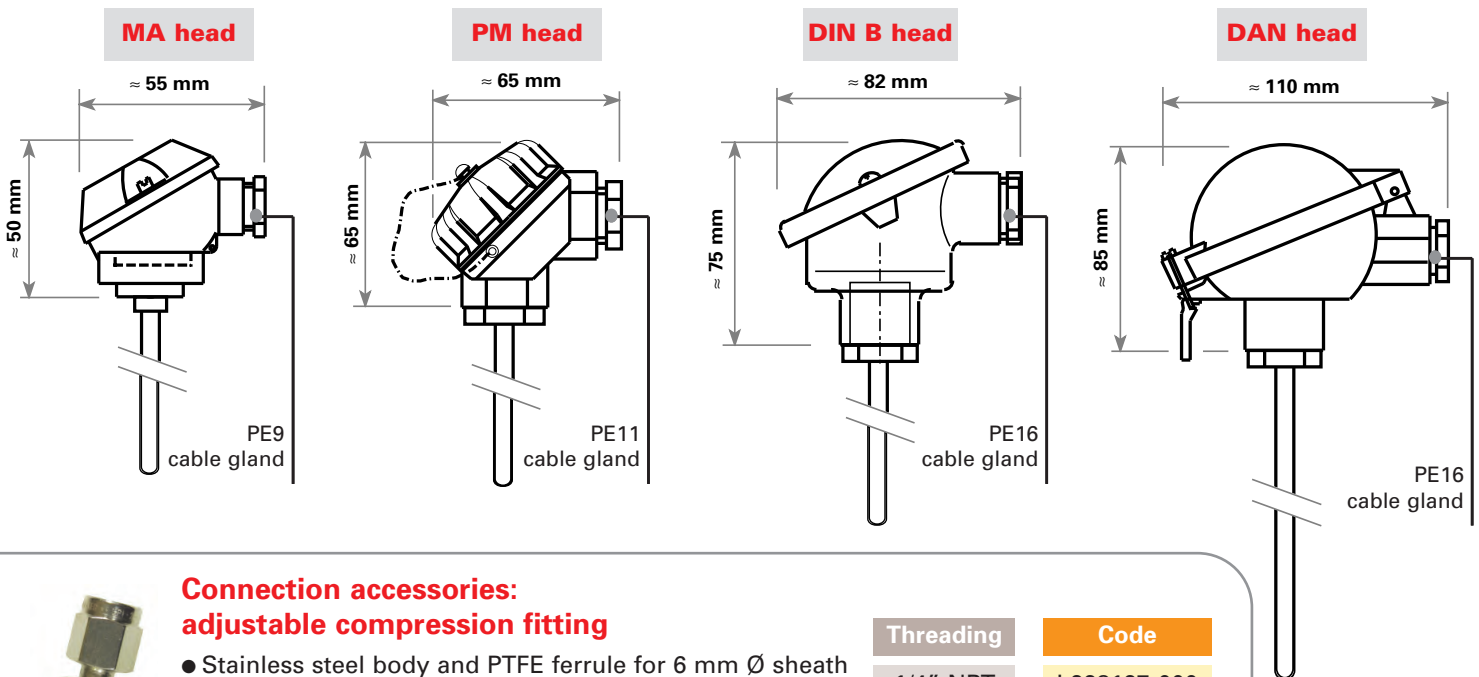

**Connection accessories:
adjustable compression fitting**

- Stainless steel body and PTFE ferrule for 6 mm Ø sheath
 - Pressure resistance: see p. 7
- Other types of connection: see connection components

Threading	Code
1/4" NPT	L228127-000
1/2" NPT	L078939-000

Description:

- RTD 100 Ω probe, class A, complies with NF EN 60751 standard
available in: simple or duplex
- 316L stainless steel protective sheathing, 6 mm diameter
available in: L1 length
- DIN format G1/2 fitting, IP54 protection
available in: MA, PM, DIN B or DAN
 - Electrical connection to terminal block: MA, PM and DIN B
 - Connection to linearised 4-20 mA output transmitter: DAN
 - PE9, PE11 or PE16 cable gland, depending on model (see p. 48)

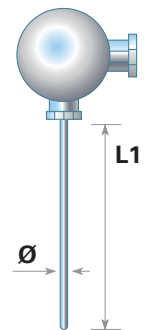

Models and codes for ordering



Probe Qty	Wiring	L1 (mm)	Ø (mm)	S51-450 MA terminal block head	S50-450 PM terminal block head	S53-450 DIN B terminal block head	S52-450 DAN head transmitter*	
1 x 100 Ω	1 x 3 wires	50	6	L335114-003	L335014-003	L335314-003	L335214-103	
		100		L335114-006	L335014-006	L335314-006	L335214-106	
		150		L335114-007	L335014-007	L335314-007	L335214-107	
		200		L335114-008	L335014-008	L335314-008	L335214-108	
		300		L335114-010	L335014-010	L335314-010	L335214-110	
		500		L335114-014	L335014-014	L335314-014	L335214-114	
2 x 100 Ω	2 x 2 wires	200		L335134-008	L335034-008			
		300		L335134-010	L335034-010			
		500		L335134-014	L335034-014			
	2 x 3 wires	200					L335344-008	
		300					L335344-010	
		500				L335344-014		

*Sensors with transmitters: indicate the temperature range, default 0-150 °C

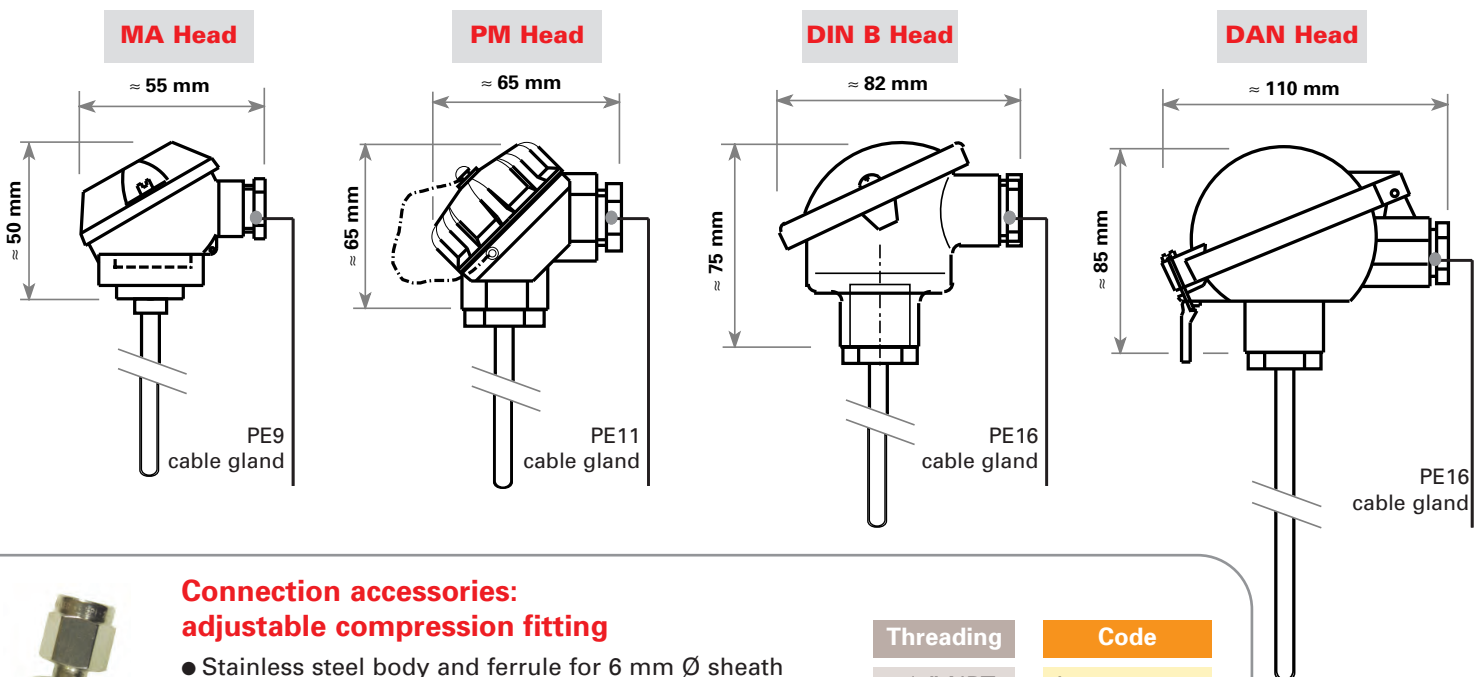

**Connection accessories:
adjustable compression fitting**

- Stainless steel body and ferrule for 6 mm Ø sheath
- Pressure resistance: see p. 7

Other types of connection: see connection components

Threading	Code
1/4" NPT	L078836-000
1/2" NPT	L078938-000

Description:

- J type thermocouple, sheathed, in compliance with NF EN 61615 standard insulated hot junction.
available in: simple (1 TC) and duplex (2 TCs)
- 304L protective stainless steel sheathing
available in: L1 length and Ø
- DIN format G1/2 fitting, IP54 protection
available in: MA, DIN B or DAN
 - Connection to terminal block: MA and DIN B
 - Connection to linearised 4-20 mA output transmitter: DAN
 - PE9 or PE16 cable gland depending on model (see p. 48)
- Withstands temperatures up to 600 °C.
Heat resistance decreases with diameter (see p. 6)

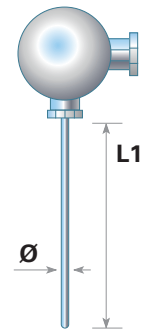

Models and codes for ordering



Probe Qty	L1 (mm)	TCG51 MA head Ø 3 mm	TCG53 DIN B head Ø 4.5 mm	TCG53 DIN B head Ø 6 mm	TCG53 DIN B head Ø 8 mm	TCG52 DAN head* Ø 4.5 mm	TCG52 DAN head* Ø 6 mm
1 x TC	250	L225125-009	L225326-009	L225327-009	L225328-009	L225226-209	L225227-209
	500	L225125-014	L225326-014	L225327-014	L225328-014	L225226-214	L225227-214
	1000	L225125-024	L225326-024	L225327-024	L225328-024	L225226-224	L225227-224
	2000	L225125-034	L225326-034	L225327-034		L225226-234	L225227-234
	3000	L225125-038	L225326-038	L225327-038		L225226-238	L225227-238
2 x TC	250	L225135-009	L225336-009	L225337-009	L225338-009		
	500	L225135-014	L225336-014	L225337-014	L225338-014		
	1000	L225135-024	L225336-024	L225337-024	L225338-024		
	2000	L225135-034	L225336-034	L225337-034			
	3000	L225135-038	L225336-038	L225337-038			

*Sensors with transmitters: indicate temperature range, default 0-500 °C

MA Head

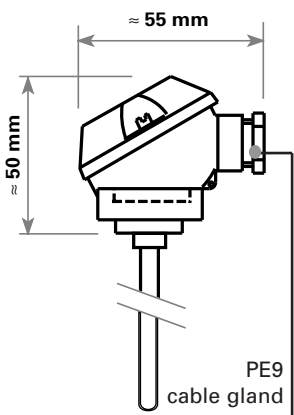

DIN B Head

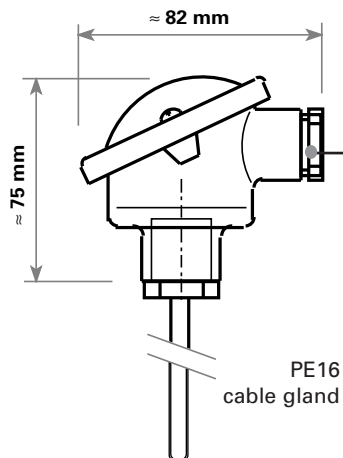

DAN Head

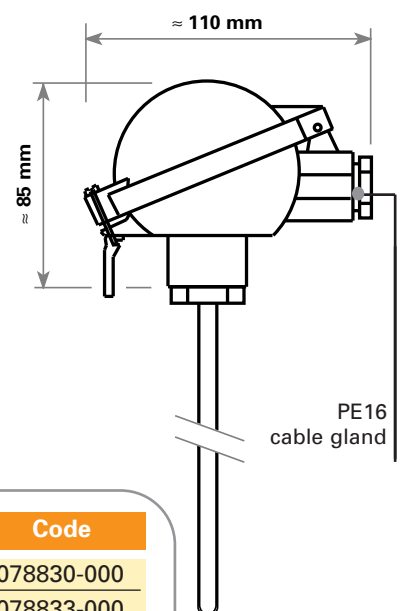

**Connection accessories:
adjustable compression fitting**



- Stainless steel body and ferrule
- Pressure resistance: see p. 7

Other types of connection:
see connection components

Threading	Sheath Ø	Code
1/4" NPT	3 mm	L078830-000
1/4" NPT	4.5 mm	L078833-000
1/4" NPT	6 mm	L078836-000
1/4" NPT	8 mm	L078841-000
1/2" NPT	6 mm	L078938-000
1/2" NPT	8 mm	L078952-000

Description:

- J type thermocouple, sheathed, in compliance with NF EN 61615 standard insulated hot junction.
available in: simple (1 TC) and duplex (2 TCs)
- protective Inconel 600 sheathing
available in: L1 length and Ø
- DIN format G1/2 fitting, IP54 protection
available in: MA, DIN B and DAN
 - Connection to terminal block: MA and DIN B
 - Connection to linearised 4-20 mA output transmitter: DAN
 - PE9 or PE16 cable gland depending on model (see p. 48)
- Withstands temperatures up to 1,100 °C.
Heat resistance decreases with diameter (see p. 6)

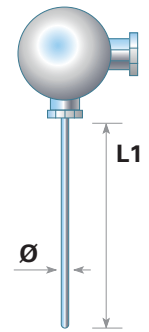

Models and codes for ordering



Probe Qty	L1 (mm)	TCG51 MA head Ø 3 mm	TCG53 DIN B head Ø 4.5 mm	TCG53 DIN B head Ø 6 mm	TCG53 DIN B head Ø 8 mm	TCG52 DAN head* Ø 4.5 mm	TCG52 DAN head* Ø 6 mm
1 x TC	250	L225155-009	L225356-009	L225357-009	L225358-009	L225256-309	L225257-309
	500	L225155-014	L225356-014	L225357-014	L225358-014	L225256-314	L225257-314
	1000	L225155-024	L225356-024	L225357-024	L225358-024	L225256-324	L225257-324
	2000	L225155-034	L225356-034	L225357-034		L225256-334	L225257-334
	3000	L225155-038	L225356-038	L225357-038		L225256-338	L225257-338
2 x TC	250	L225175-009	L225376-009	L225377-009	L225378-009		
	500	L225175-014	L225376-014	L225377-014	L225378-014		
	1000	L225175-024	L225376-024	L225377-024	L225378-024		
	2000	L225175-034	L225376-034	L225377-034			
	3000	L225175-038	L225376-038	L225377-038			

*Sensors with transmitters: indicate temperature range, default 0-1,200 °C

MA head

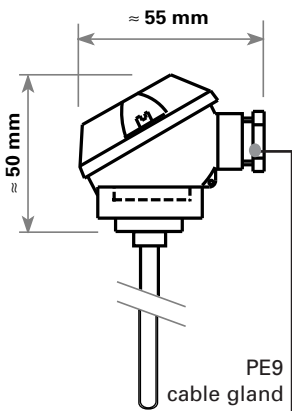

DIN B head

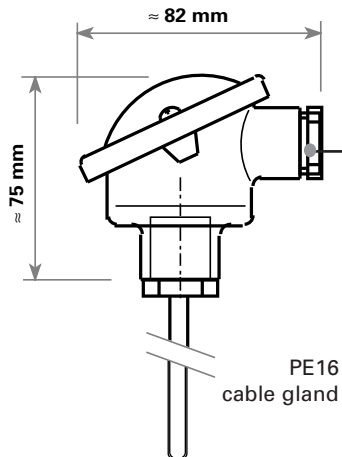

DAN head

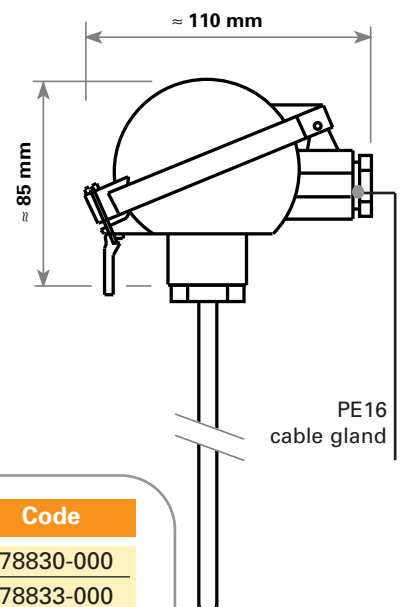

Connection accessories: adjustable compression fitting

- Stainless steel body and ferrule
- Pressure resistance: see p. 7

Other types of connection:
see connection components



Threading	Sheath Ø	Code
1/4" NPT	3 mm	L078830-000
1/4" NPT	4.5 mm	L078833-000
1/4" NPT	6 mm	L078836-000
1/4" NPT	8 mm	L078841-000
1/2" NPT	6 mm	L078938-000
1/2" NPT	8 mm	L078952-000

Description:

- RTD 100 Ω probe, class A, in compliance with NF EN 60751
available in: simple and duplex
- 316L stainless steel protective sheathing, 6 mm diameter
available in: L1 length
- DIN format G1/2 fitting, IP54 protection
available in: PM, DIN B or DAN
 - Electrical connection to terminal block: PM et DIN B
 - Connection to linearised 4-20 mA output transmitter: DAN
 - PE11 or PE16 cable gland depending on model (*see p. 48*)
- Connection via G1/2 fitting, G1/2 threading

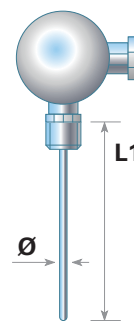

**Models and codes
for ordering**

Probe Qty	Wiring	L1 (mm)	Ø (mm)	S90-200 Terminal block PM head	S93-200 Terminal block DIN B head	S92-200 Transmitter DAN head*
1 x 100 Ω	1 x 3 wires	50	6	L309014-003	L309314-003	L309214-103
		100		L309014-006	L309314-006	L309214-106
		150		L309014-007	L309314-007	L309214-107
		200		L309014-008	L309314-008	L309214-108
		300		L309014-010	L309314-010	L309214-110
2 x 100 Ω	2 x 2 wires	500		L309014-014	L309314-014	L309214-114
		200		L309034-008		
		300		L309034-010		
	2 x 3 wires	200			L309344-008	
		300			L309344-010	
		500			L309344-014	

*Sensors with transmitters: indicate temperature range, default 0-150 °C

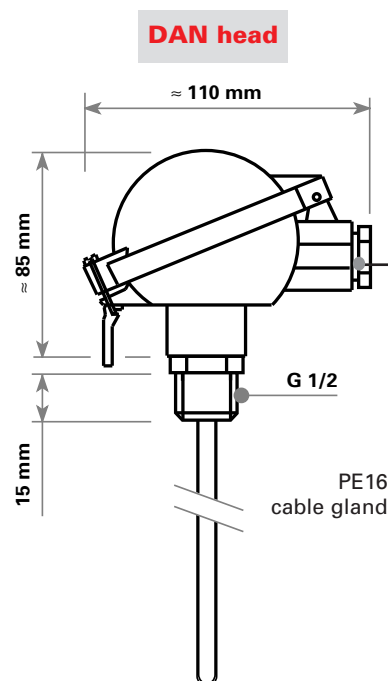
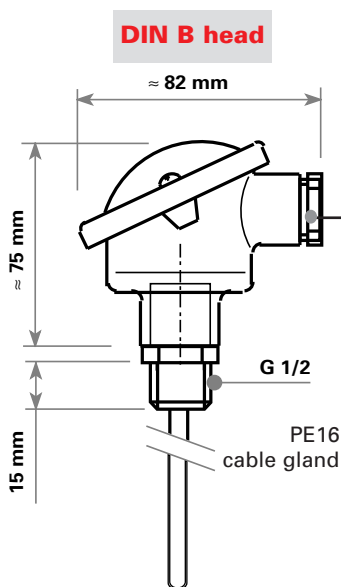
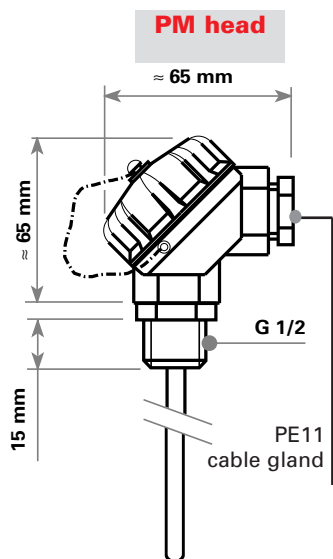

Description:

- RTD 100 Ω probe, class A, in compliance with NF EN 60751
available in: simple and duplex
- 316L stainless steel protective sheathing, 6 mm diameter
available in: L1 length
- DIN format G1/2 fitting, IP54 protection
available in: PM, DIN B and DAN
 - Electrical connection to terminal block: PM et DIN B
 - Connection to linearised 4-20 mA output transmitter: DAN
 - PE11 or PE16 cable gland depending on model (see p. 48)
- Connection via G1/2 fitting, G1/2 threading

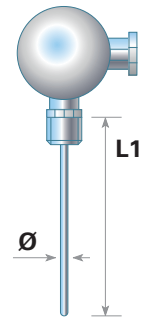

Models and codes for ordering



Probe Qty	Wiring	L1 (mm)	Ø (mm)	S90-450 Terminal block PM head	S93-450 Terminal block DIN B head	S92-450 Transmitter DAN head*
1 x 100 Ω	1 x 3 wires	50	6	L339014-003	L339314-003	L339214-103
		100		L339014-006	L339314-006	L339214-106
		150		L339014-007	L339314-007	L339214-107
		200		L339014-008	L339314-008	L339214-108
		300		L339014-010	L339314-010	L339214-110
2 x 100 Ω	2 x 2 wires	500		L339014-014	L339314-014	L339214-114
		200		L339034-008		
		300		L339034-010		
	2 x 3 wires	200			L339344-008	
		300			L339344-010	
		500			L339344-014	

*Sensors with transmitters: indicate temperature range, default 0-150 °C

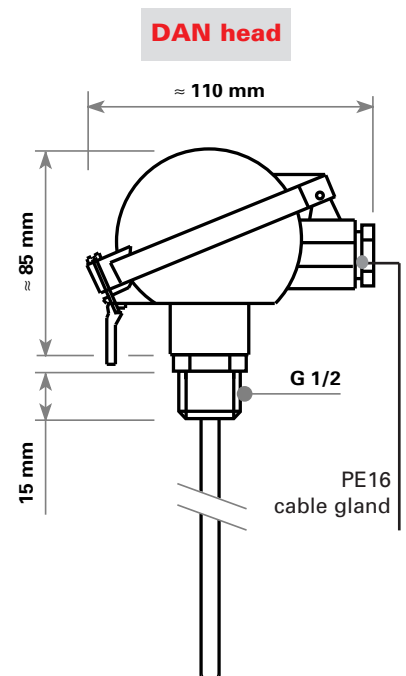
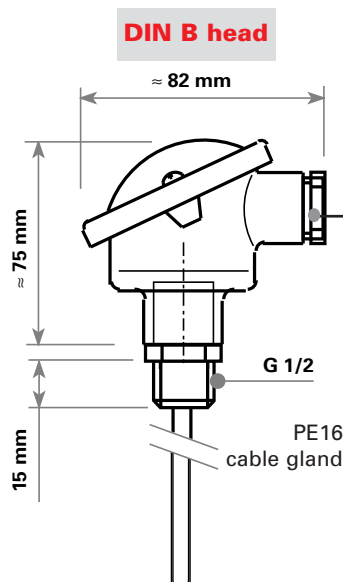
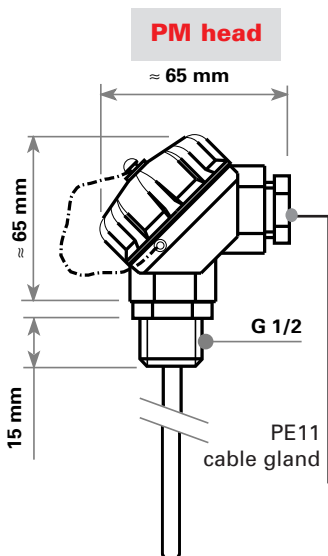

Description:

- J type thermocouple, sheathed, in compliance with NF EN 61615 standard insulated hot junction.
available in: simple (1 TC) and duplex (2 TCs)
- 304L protective stainless steel sheathing
available in: L1 length and Ø
- DIN format G1/2 fitting, IP54 protection
available in: DIN B or DAN
 - Connection to terminal block: DIN B
 - Connection to linearised 4-20 mA output transmitter: DAN
 - PE16 cable gland (see p. 48)
- Connection via G1/2 fitting, G 1/2 threading
- Withstands temperatures up to 600 °C
Heat resistance decreases with diameter (see p. 6)

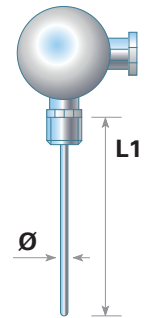

Models and codes for ordering



TC Qty	L1 (mm)	TCG93 DIN B head			TCG92 DAN head*	
		Ø 4.5 mm	Ø 6 mm	Ø 8 mm	Ø 4.5 mm	Ø 6 mm
1 x TC	250	L229326-009	L229327-009	L229328-009	L229226-209	L229227-209
	500	L229326-014	L229327-014	L229328-014	L229226-214	L229227-214
	1000	L229326-024	L229327-024	L229328-024	L229226-224	L229227-224
	2000	L229326-034	L229327-034		L229226-234	L229227-234
	3000	L229326-038	L229327-038		L229226-238	L229227-238
2 x TC	250	L229336-009	L229337-009	L229338-009		
	500	L229336-014	L229337-014	L229338-014		
	1000	L229336-024	L229337-024	L229338-024		
	2000	L229336-034	L229337-034			
	3000	L229336-038	L229337-038			

*Sensors with transmitters: indicate temperature range, default 0-500 °C

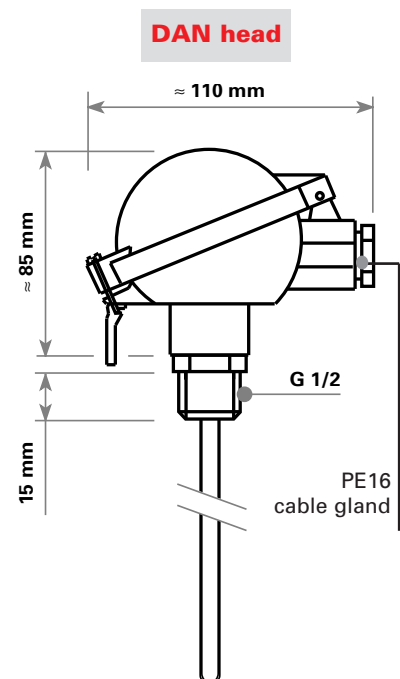
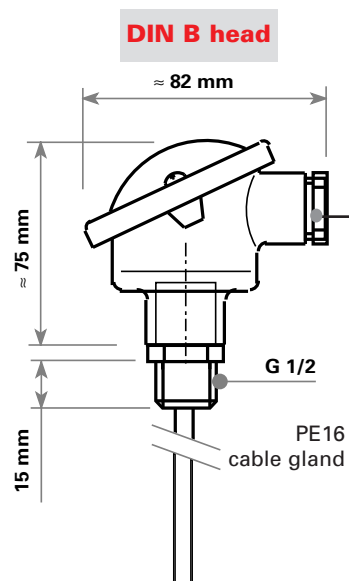

Description:

- K type thermocouple, sheathed, in compliance with NF EN 61615 standard insulated hot junction.
available in: simple (1 TC) and duplex (2 TCs)
- Protective Inconel 600 sheathing
available in: L1 length and Ø
- DIN format G1/2 fitting, IP54 protection
available in: DIN B and DAN
 - Connection to terminal block: DIN B
 - Connection to linearised 4-20 mA output transmitter: DAN
 - PE16 cable gland (see p. 48)
- Connection via G1/2 fitting, G 1/2 threading
- Withstands temperatures up to 1,100 °C
Heat resistance decreases with diameter (see p. 6)

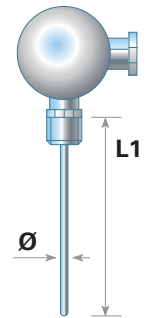

**Models and codes
for ordering**



TC Qty	L1 (mm)	TCG93			TCG92	
		DIN B head Ø 4.5 mm	DIN B head Ø 6 mm	DIN B head Ø 8 mm	DAN head* Ø 4.5 mm	DAN head* Ø 6 mm
1 x TC	250	L229356-009	L229357-009	L229358-009	L229256-309	L229257-309
	500	L229356-014	L229357-014	L229358-014	L229256-314	L229257-314
	1000	L229356-024	L229357-024	L229358-024	L229256-324	L229257-324
	2000	L229356-034	L229357-034		L229256-334	L229257-334
	3000	L229356-038	L229357-038		L229256-338	L229257-338
2 x TC	250	L229376-009	L229377-009	L229378-009		
	500	L229376-014	L229377-014	L229378-014		
	1000	L229376-024	L229377-024	L229378-024		
	2000	L229376-034	L229377-034			
	3000	L229376-038	L229377-038			

*Sensors with transmitters: indicate temperature range, default 0-1200 °C

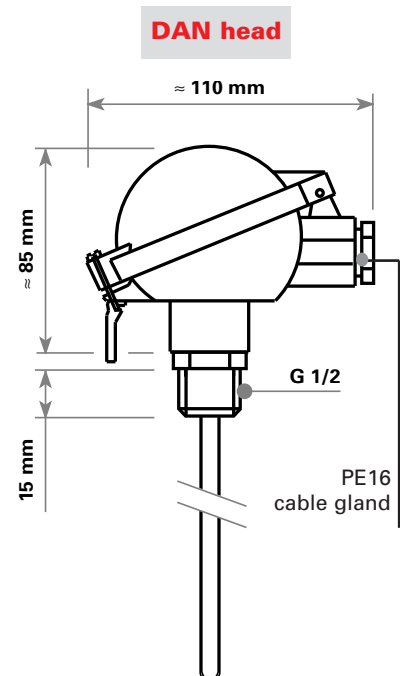
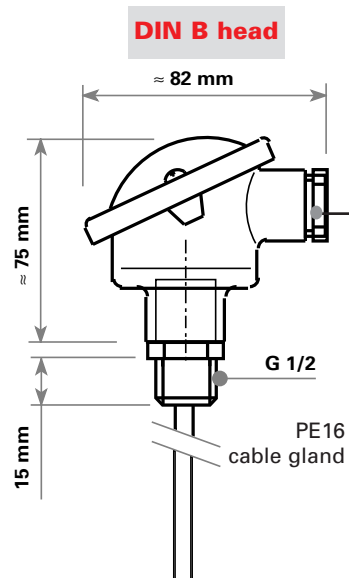

Description:

- RTD 100 Ω probe, class A, in compliance with NF EN 60751
1 x 3-wire connection (simple)
- 316L stainless steel protective sheathing, 6 mm diameter
available in: L1 length
- Cable length: 2 m
available in: PVC, silicone and FEP

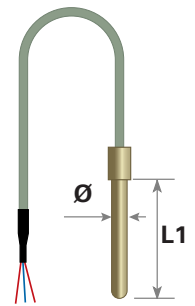
**Models and codes
for ordering**

Probe Qty	Wiring	L1 (mm)	Ø (mm)	S20-100 Max. temp. 100 °C PVC cable	S21-200 Max. temp. 200 °C Silicon cable	S22-200 Max. temp. 200 °C FEP cable
1 x 100 Ω	1 x 3 wires	50	6	L302014-503	L302114-503	L302214-503
		100		L302014-506	L302114-506	L302214-506
		200		L302014-508	L302114-508	L302214-508
		300		L302014-510	L302114-510	L302214-510
		500		L302014-514	L302114-514	L302214-514

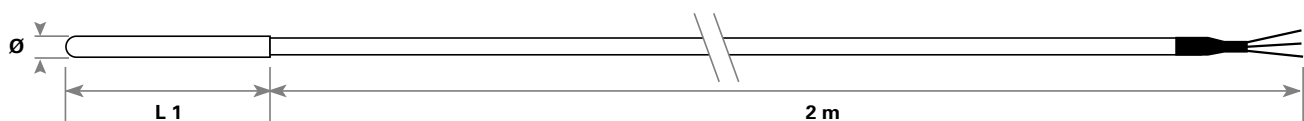
**Connection accessories:
adjustable compression fitting**

- Stainless steel body and PTFE ferrule for 6 mm \varnothing sheath
- Pressure resistance: see p. 7

Other types of connection: see connection components

Electrical connection accessories:

- Standard three pin connector

Other types of electrical connection: see electrical connection

Threading	Code
1/4" NPT	L228127-000
1/2" NPT	L078939-000

Code
L018290-000



Description:

- RTD 100 Ω probe, class A, in compliance with NF EN 60751
available in: 1 x 3 wires (simple) and 2 x 3 wires (duplex)
- 316L stainless steel protective sheathing
available in: L1 length and Ø
- Cable length: 2 m
available in: PVC, silicone and FEP

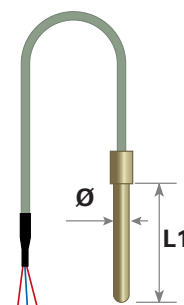

Models and codes for ordering

Probe Qty	Wiring	L1 (mm)	Ø (mm)	S1 PVC cable	S11 Silicon cable	S12 FEP cable
1 x 100 Ω	1 x 3 wires	50	1.6	L330111-503		
		100		L330111-506		
		150		L330111-507		
		250	L330111-509			
		50	3	L330112-503	L331112-503	L331212-503
		100		L330112-506	L331112-506	L331212-506
		150		L330112-507	L331112-507	L331212-507
		200	L330112-508	L331112-508	L331212-508	
		100	4.5	L330113-506	L331113-506	L331213-506
	200	L330113-508		L331113-508	L331213-508	
	300	L330113-510		L331113-510	L331213-510	
	500	L330113-514	L331113-514	L331213-514		
	50	6	L330114-503	L331114-503	L331214-503	
	100		L330114-506	L331114-506	L331214-506	
	150		L330114-507	L331114-507	L331214-507	
	200		L330114-508	L331114-508	L331214-508	
	300	L330114-510	L331114-510	L331214-510		
	500	L330114-514	L331114-514	L331214-514		
2 x 100 Ω	2 x 3 wires	200	6	L330144-508		L331244-508
		300		L330144-510		L331244-510
		500		L330144-514		L331244-514

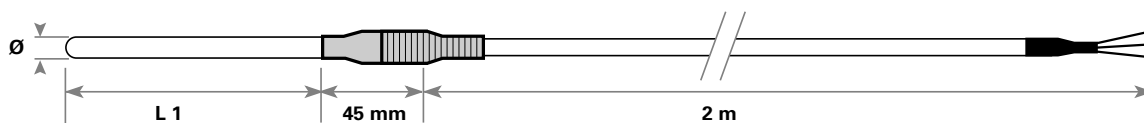

**Connection accessories:
adjustable compression fitting**

- Stainless steel body and ferrule
- Pressure resistance: see p. 7

Threading	Sheath Ø	Code
1/4" NPT	3 mm	L078830-000
1/4" NPT	4.5 mm	L078833-000
1/4" NPT	6 mm	L078836-000
1/2" NPT	6 mm	L078938-000

Other types of connection: see connection components



Electrical connection accessories:

- Standard three-pin connector

Code
L018290-000

Other types of electrical connection: see electrical connection

Description:

- J type thermocouple, sheathed, in compliance with NF EN 61615 standard insulated hot junction.
available in: simple (1 TC) and duplex (2 TCs)
- 304L protective stainless steel sheathing
available in: L1 length and Ø
- 2 m long PVC cable, with copper braid
- Withstands temperatures up to 600 °C
Heat resistance decreases with diameter (see p. 6)

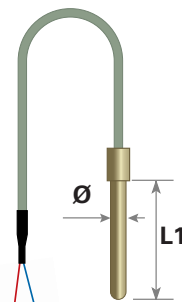

Models and codes for ordering

TC Qty	L1 (mm)	TCG3J Ø 1 mm	TCG3J Ø 1.5 mm	TCG3J Ø 2 mm	TCG3J Ø 3 mm	TCG3J Ø 4.5 mm	TCG3J Ø 6 mm	TCG3J Ø 8 mm
1 x TC	250	L220322-509	L220323-509	L220324-509	L220325-509	L220326-509	L220327-509	L220328-509
	500	L220322-514	L220323-514	L220324-514	L220325-514	L220326-514	L220327-514	L220328-514
	1000	L220322-524	L220323-524	L220324-524	L220325-524	L220326-524	L220327-524	L220328-524
	2000	L220322-534	L220323-534	L220324-534	L220325-534	L220326-534	L220327-534	
	3000	L220322-538	L220323-538	L220324-538	L220325-538	L220326-538	L220327-538	
2 x TC	250			L220334-509	L220335-509	L220336-509	L220337-509	L220338-509
	500			L220334-514	L220335-514	L220336-514	L220337-514	L220338-514
	1000			L220334-524	L220335-524	L220336-524	L220337-524	L220338-524
	2000			L220334-534	L220335-534	L220336-534	L220337-534	
	3000			L220334-538	L220335-538	L220336-538	L220337-538	

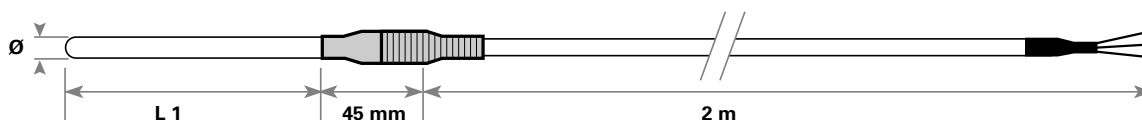

**Connection accessories:
adjustable compression fitting**

- Stainless steel body and ferrule
- Pressure resistance: see p. 7

Other types of connection:
see connection components

Threading	Sheath Ø	Code
1/8" NPT	1.5 mm	L078827-000
1/8" NPT	2 mm	L078828-000
1/8" NPT	3 mm	L078830-000
1/4" NPT	4.5 mm	L078833-000
1/4" NPT	6 mm	L078836-000
1/4" NPT	8 mm	L078841-000
1/2" NPT	6 mm	L078938-000
1/2" NPT	8 mm	L078952-000



Electrical connection accessories:

- Standard or miniature connector, 2 pins, male or female, simple or duplex

Other types of electrical connection:
see electrical connection

1 or 2 TC	Type	Nature	Code
1 TC	Standard	Male	L12547J-000
		Female	L12548J-000
2 TC	Miniature	Male	L12587J-000
		Female	L12588J-000
	Standard	Male	L12543J-000
		Female	L12544J-000

Description:

- J type thermocouple, sheathed, in compliance with NF EN 61615 standard insulated hot junction. Simple (1 TC)
- 304L protective stainless steel sheathing
available in: L1 length and Ø
- **TCG31J model** (0.5 mm Ø): PTFE insulated TC wires, 2 m long
- **TCG32J model** (Ø > 0.5 mm): 2 m long FEP cable, fiberglass insulation with copper braid
- Withstands temperatures up to 450 °C
Heat resistance decreases with diameter (see p. 6)

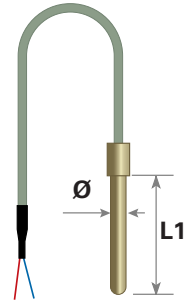

Models and codes for ordering

TC Qty	L1 (mm)	TCG31J Ø 0.5 mm	TCG32J Ø 1 mm	TCG32J Ø 1.5 mm	TCG32J Ø 2 mm	TCG32J Ø 3 mm
1 x TC	150	L223121-507				
	250	L223121-509	L223222-509	L223223-509	L223224-509	L223225-509
	500	L223121-514	L223222-514	L223223-514	L223224-514	L223225-514
	1000	L223121-524	L223222-524	L223223-524	L223224-524	L223225-524

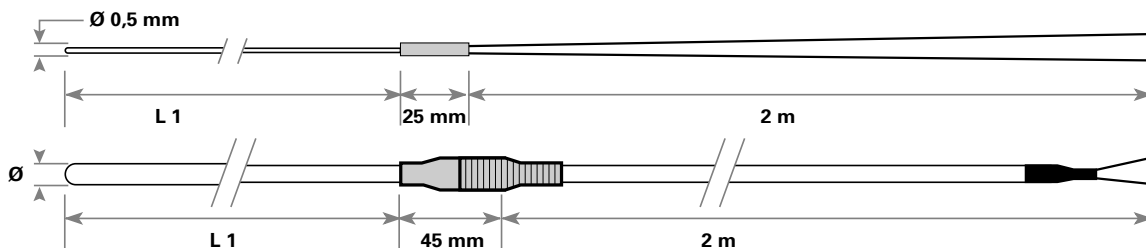

**Connection accessories:
adjustable compression fitting**

- Stainless steel body and ferrule
- Pressure resistance: see p. 7

Other types of connection: see connection components

Threading	Sheath Ø	Code
1/8" NPT	1.5 mm	L078827-000
1/8" NPT	2 mm	L078828-000
1/4" NPT	3 mm	L078830-000

Electrical connection accessories:

- Standard or miniature connector, 2 pins, male or female, simple or duplex

Other types of electrical connection: see electrical connection

1 or 2 TC	Type	Nature	Code
1 TC	Standard	Male	L12547J-000
		Female	L12548J-000
	Miniature	Male	L12587J-000
		Female	L12588J-000



Description:

- K type thermocouple, sheathed, in compliance with NF EN 61615 standard insulated hot junction
available in: simple (1 TC) and duplex (2 TCs)
- Protective Inconel 600 sheathing
available in: L1 length and Ø
- 2 m long PVC cable, with copper braid
- Withstands temperatures up to 1,100 °C
Heat resistance decreases with diameter (see p. 6)

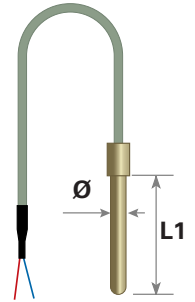

Models and codes for ordering

TC Qty	L1 (mm)	TCG3K Ø 1 mm	TCG3K Ø 1.5 mm	TCG3K Ø 2 mm	TCG3K Ø 3 mm	TCG3K Ø 4.5 mm	TCG3K Ø 6 mm	TCG3K Ø 8 mm
1 x TC	250	L220352-509	L220353-509	L220354-509	L220355-509	L220356-509	L220357-509	L220358-509
	500	L220352-514	L220353-514	L220354-514	L220355-514	L220356-514	L220357-514	L220358-514
	1000	L220352-524	L220353-524	L220354-524	L220355-524	L220356-524	L220357-524	L220358-524
	2000	L220352-534	L220353-534	L220354-534	L220355-534	L220356-534	L220357-534	L220358-534
	3000	L220352-538	L220353-538	L220354-538	L220355-538	L220356-538	L220357-538	L220358-538
2 x TC	250			L220364-509	L220365-509	L220366-509	L220367-509	L220368-509
	500			L220364-514	L220365-514	L220366-514	L220367-514	L220368-514
	1000			L220364-524	L220365-524	L220366-524	L220367-524	L220368-524
	2000			L220364-534	L220365-534	L220366-534	L220367-534	L220368-534
	3000			L220364-538	L220365-538	L220366-538	L220367-538	L220368-538

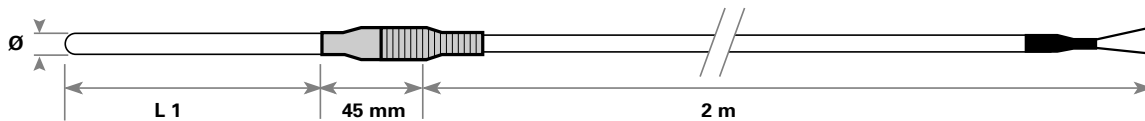

**Connection accessories:
adjustable compression fitting**

- Stainless steel body and ferrule
- Pressure resistance: see p. 7

Other types of connection:
see connection components

Threading	Sheath Ø	Code
1/8" NPT	1.5 mm	L078827-000
1/8" NPT	2 mm	L078828-000
1/8" NPT	3 mm	L078830-000
1/4" NPT	4.5 mm	L078833-000
1/4" NPT	6 mm	L078836-000
1/4" NPT	8 mm	L078841-000
1/2" NPT	6 mm	L078938-000
1/2" NPT	8 mm	L078952-000



Electrical connection accessories:

- Standard or miniature connector, 2 pins, male or female, simple or duplex

Other types of electrical connection:
see electrical connection

1 or 2 TC	Type	Nature	Code
1 TC	Standard	Male	L12547K-000
		Female	L12548K-000
2 TC	Miniature	Male	L12587K-000
		Female	L12588K-000
	Standard	Male	L12543K-000
		Female	L12544K-000

Description:

- K type thermocouple, sheathed, in compliance with NF EN 61615 standard insulated hot junction
available in: simple (1 TC) and duplex (2 TCs)
- Protective Inconel 600 sheathing
available in: L1 length and Ø
- **Model TCG31K** (0.5 mm Ø): PTFE insulated TC wires, 2 m long
- **Model TCG32K** (Ø > 0.5 mm): 2 m long FEP cable, fiberglass insulation with copper braid
- Withstands temperatures up to 750 °C
Heat resistance decreases with diameter (see p. 6)

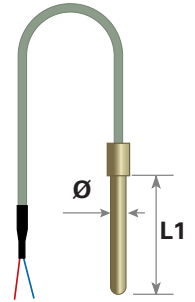

Models and codes for ordering

TC Qty	L1 (mm)	TCG31K Ø 0.5 mm	TCG32K Ø 1 mm	TCG32K Ø 1.5 mm	TCG32K Ø 2 mm	TCG32K Ø 3 mm
1 x TC	150	L223151-507				
	250	L223151-509	L223252-509	L223253-509	L223254-509	L223255-509
	500	L223151-514	L223252-514	L223253-514	L223254-514	L223255-514
	1000	L223151-524	L223252-524	L223253-524	L223254-524	L223255-524
2 x TC	250				L223264-509	L223265-509
	500				L223264-514	L223265-514
	1000				L223264-524	L223265-524

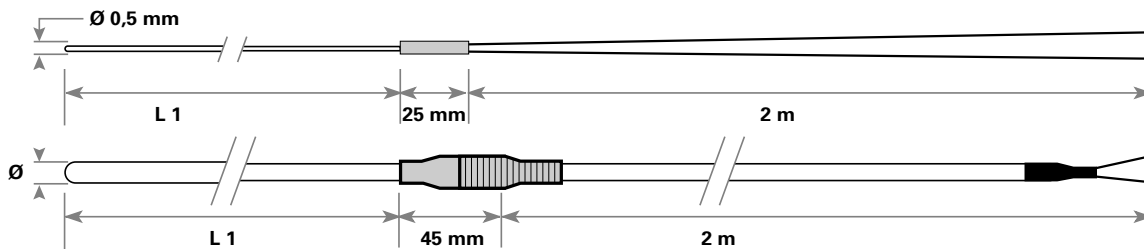

**Connection accessories:
adjustable compression fitting**

- Stainless steel body and ferrule
- Pressure resistance: see p. 7

Other types of connection: see connection components

Threading	Sheath Ø	Code
1/8" NPT	1.5 mm	L078827-000
1/8" NPT	2 mm	L078828-000
1/4" NPT	3 mm	L078830-000



Electrical connection accessories:

- Standard or miniature connector, 2 pins, male or female, simple or duplex

Other types of electrical connection: see electrical connection

1 or 2 TC	Type	Nature	Code
1 TC	Standard	Male	L12547K-000
		Female	L12548K-000
2 TC	Miniature	Male	L12587K-000
		Female	L12588K-000
	Standard	Male	L12543K-000
		Female	L12544K-000

Description:

- RTD 100 Ω probe, class A, in compliance with NF EN 60751 standard
1 x 3-wire connection (simple)
- 316L stainless steel protective sheathing, 6 mm diameter
available in: L1 length
- Connector
available in: standard 3-pin, Lemo (size 2, ref. PC2.M3)
or Jaeger (ref. 0532.203)

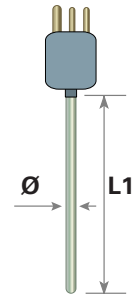

**Models and codes
for ordering**



Probe Qty	Wiring	L1 (mm)	Ø (mm)	S44-200 Standard 3-pin connector	S40-200 Size 2 Lemo connector ref. PC2.M3	S41-200 Jaeger connector ref. 0532.203
1 x 100 Ω	1 x 3 wires	50	6	L304414-003	L304014-003	L304114-003
		100		L304414-006	L304014-006	L304114-006
		150		L304414-007	L304014-007	L304114-007
		200		L304414-008	L304014-008	L304114-008
		300		L304414-010	L304014-010	L304114-010
		500		L304414-014	L304014-014	L304114-014

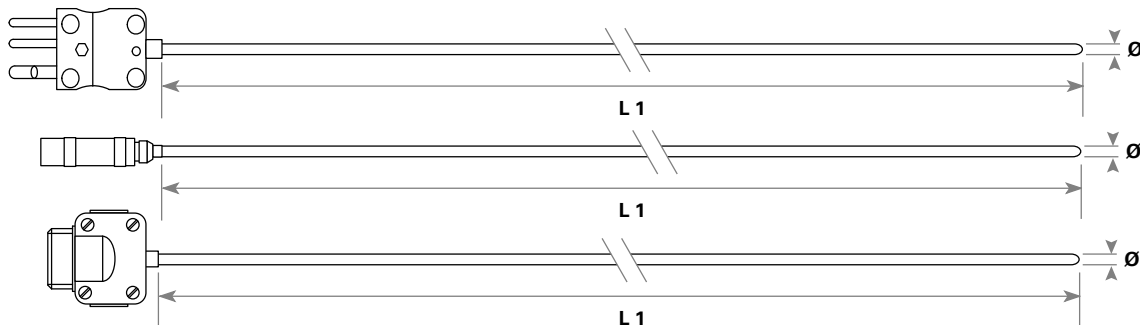

**Connection accessories:
adjustable compression fitting**

- Stainless steel body and PTFE ferrule for 6 mm Ø sheath
- Pressure resistance: see p. 7

Other types of connection: see connection components

Threading	Code
1/4" NPT	L228127-000
1/2" NPT	L078939-000

Electrical connection accessories:

Type of connector	Code	Extension cable	Code
Std female 3-pin	L018211-004	Female Std/naked wire 2 m long	L261312-200
Female Jaeger	L018109-000	Female Jaeger/naked wire 2 m long	L265312-200
F2M3 Lemo plug	L018431-000	Size 2 Lemo plug/naked wire 2 m long	L264312-200

Other types of electrical connection: see electrical connection

Description:

- RTD 100 Ω probe, class A, in compliance with NF EN 60751
1 x 3-wire connection (simple)
- 316L stainless steel protective sheathing
available in: L1 length and Ø
- Connector
available in: Miniature 3-pin, Standard 3-pin,
Lemo (size 2, ref. PC2.M3) or Jaeger (ref. 0532.203)

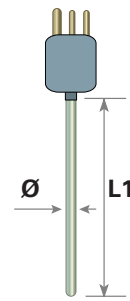

**Models and codes
for ordering**



Probe Qty	Wiring	L1 (mm)	Ø (mm)	S43-450 Miniature 3-pin connector	S44-450 Standard 3-pin connector	S40-450 Size 2 Lemo connector ref. PC2M3	S41-450 Jaeger connector ref. 0532.203
1 x 100 Ω	1 x 3 wires	50	3	L334312-003	L334412-003	L334012-003	L334112-003
		100		L334312-006	L334412-006	L334012-006	L334112-006
		150		L334312-007	L334412-007	L334012-007	L334112-007
		200		L334312-008	L334412-008	L334012-008	L334112-008
		300		L334312-010	L334412-010	L334012-010	L334112-010
		500		L334312-014	L334412-014	L334012-014	L334112-014
		50	6		L334414-003	L334014-003	L334114-003
		100		L334414-006	L334014-006	L334114-006	
		150		L334414-007	L334014-007	L334114-007	
		200		L334414-008	L334014-008	L334114-008	
		300		L334414-010	L334014-010	L334114-010	
		500		L334414-014	L334014-014	L334114-014	

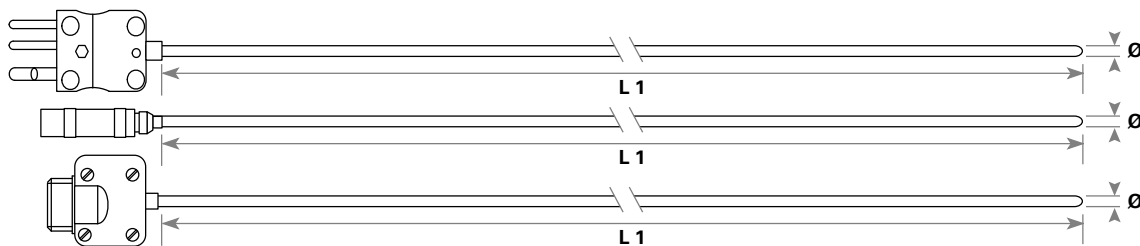

Connection accessories: adjustable compression fitting

- Stainless steel body and ferrule
- Pressure resistance: see p. 7

Other types of connection:
see connection components

Threading	Sheath Ø	Code
1/4" NPT	3 mm	L078830-000
1/4" NPT	6 mm	L078836-000
1/2" NPT	6 mm	L078938-000

Electrical connection accessories:

Type of connector	Code	Extension cable	Code
Mini female 3-pin	L018200-005	Female std/naked wire 2 m long	L261312-200
Std female 3-pin	L018211-004	Female Jaeger/naked wire 2 m long	L265312-200
Jaeger female	L018109-000	Size 2 Lemo plug/naked wire 2 m long	L264312-200
F2M3 Lemo plug	L018431-000		

Other types of electrical connection: see electrical connection

Description:

- J type thermocouple, sheathed, in compliance with NF EN 61615 standard insulated hot junction. Simple (1 TC)
- 304L protective stainless steel sheathing
available in: L1 length and Ø
- Miniature male connector
- Withstands temperatures up to 300 °C
Heat resistance decreases with diameter (see p. 6)

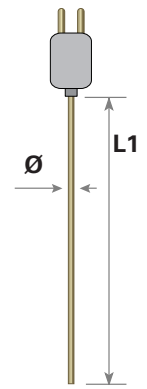

Models and codes for ordering

TC Qty	L1 (mm)	TCG11J Ø 1 mm	TCG11J Ø 1.5 mm	TCG11J Ø 2 mm
1 x TC	250	L221122-009	L221123-009	L221124-009
	500	L221122-014	L221123-014	L221124-014
	1000	L221122-024	L221123-024	L221124-024
	2000	L221122-034	L221123-034	L221124-034
	3000	L221122-038	L221123-038	L221124-038

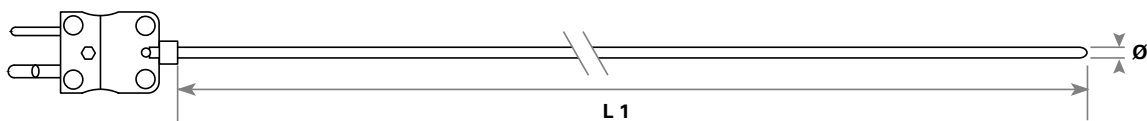

**Connection accessories:
adjustable compression fitting**

- Stainless steel body and ferrule
- Pressure resistance: see p. 7

Other types of connection:
see connection components

Threading	Sheath Ø	Code
1/8" NPT	1,5 mm	L078827-000
1/8" NPT	2 mm	L078828-000



Electrical connection accessories:

Connector	Code	Extension cable	Code
J miniature female connector	L12588J-000	J thermocouple, miniature female connector/naked wire, 2 m long PVC cable	L262J12-200

Other types of electrical connection: see electrical connection

Description:

- J type thermocouple, sheathed, in compliance with NF EN 61615 standard insulated hot junction
available in: simple (1 TC) and duplex (2 TCs)
- 304L protective stainless steel sheathing
available in: L1 length and Ø
- Standard male connector
- Withstands temperatures up to 600 °C
Heat resistance decreases with diameter (see p. 6)

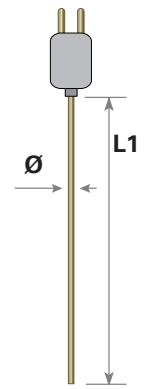

Models and codes for ordering

TC Qty	L1 (mm)	TCG6J Ø 2 mm	TCG6J Ø 3 mm	TCG6J Ø 4.5 mm	TCG6J Ø 6 mm
1 x TC	250	L220624-009	L220625-009	L220626-009	L220627-009
	500	L220624-014	L220625-014	L220626-014	L220627-014
	1000	L220624-024	L220625-024	L220626-024	L220627-024
	2000	L220624-034	L220625-034	L220626-034	L220627-034
	3000	L220624-038	L220625-038	L220626-038	L220627-038
2 x TC	250	L220634-009	L220635-009	L220636-009	L220637-009
	500	L220634-014	L220635-014	L220636-014	L220637-014
	1000	L220634-024	L220635-024	L220636-024	L220637-024
	2000	L220634-034	L220635-034	L220636-034	L220637-034
	3000	L220634-038	L220635-038	L220636-038	L220637-038

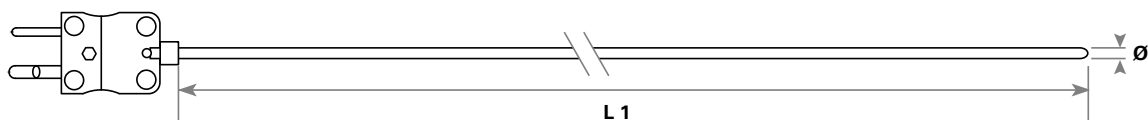

Connection accessories: adjustable compression fitting



- Stainless steel body and ferrule
- Pressure resistance: see p. 7

Other types of connection:
see connection components

Threading	Sheath Ø	Code
1/8" NPT	2 mm	L078828-000
1/4" NPT	3 mm	L078830-000
1/4" NPT	4.5 mm	L078833-000
1/4" NPT	6 mm	L078836-000
1/2" NPT	6 mm	L078938-000

Electrical connection accessories:



Connector	Code
J standard female connector	L12548J-000
J duplex standard female connector	L12544J-000

Extension cable	Code
J thermocouple, standard female connector/naked wire, 2 m long PVC cable	L261J12-200
J duplex thermocouple, standard female connector/naked wire, 2 m long PVC cable	L271J12-200

Other types of electrical connection: see electrical connection

Description:

- K type thermocouple, sheathed, in compliance with NF EN 61615 standard insulated hot junction. Simple (1 TC)
- Protective Inconel 600 sheathing
available in: L1 length and Ø
- Miniature male connector
- Withstands temperatures up to 500 °C
Heat resistance decreases with diameter (see p. 6)

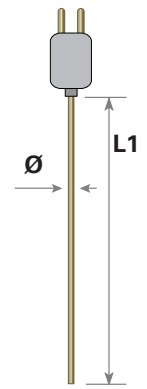

**Models and codes
for ordering**

TC Qty	L1 (mm)	TCG11K Ø 1 mm	TCG11K Ø 1.5 mm	TCG11K Ø 2 mm
1 x TC	250	L221152-009	L221153-009	L221154-009
	500	L221152-014	L221153-014	L221154-014
	1000	L221152-024	L221153-024	L221154-024
	2000	L221152-034	L221153-034	L221154-034
	3000	L221152-038	L221153-038	L221154-038

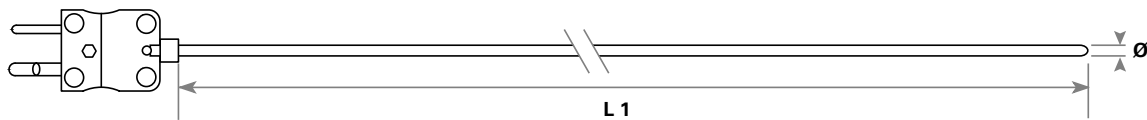

**Connection accessories:
adjustable compression fitting**

- Stainless steel body and ferrule
- Pressure resistance: see p. 7

Other types of connection:
see connection components

Threading	Sheath Ø	Code
1/8" NPT	1.5 mm	L078827-000
1/4" NPT	2 mm	L078828-000



Electrical connection accessories:

Connector	Code	Extension cable	Code
K miniature female connector	L12588K-000	K thermocouple, miniature female connector/naked wire, 2 m long	L262K12-200

Other types of electrical connection: see electrical connection

Description:

- K type thermocouple, sheathed, in compliance with NF EN 61615 standard insulated hot junction
available in: simple (1 TC) and duplex (2 TCs)
- Protective Inconel 600 sheathing
available in: L1 length and Ø
- Standard male connector
- Withstands temperatures up to 1,100 °C
Heat resistance decreases with diameter (see p. 6)

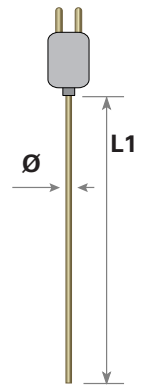

Models and codes for ordering



TC Qty	L1 (mm)	TCG6K Ø 2 mm	TCG6K Ø 3 mm	TCG6K Ø 4.5 mm	TCG6K Ø 6 mm
1 x TC	250	L220654-009	L220655-009	L220656-009	L220657-009
	500	L220654-014	L220655-014	L220656-014	L220657-014
	1000	L220654-024	L220655-024	L220656-024	L220657-024
	2000	L220654-034	L220655-034	L220656-034	L220657-034
	3000	L220654-038	L220655-038	L220656-038	L220657-038
2 x TC	250	L220664-009	L220665-009	L220666-009	L220667-009
	500	L220664-014	L220665-014	L220666-014	L220667-014
	1000	L220664-024	L220665-024	L220666-024	L220667-024
	2000	L220664-034	L220665-034	L220666-034	L220667-034
	3000	L220664-038	L220665-038	L220666-038	L220667-038



Connection accessories: adjustable compression fitting



- Stainless steel body and ferrule
- Pressure resistance: see p. 7

Other types of connection: see connection components

Threading	Sheath Ø	Code
1/4" NPT	3 mm	L078830-000
1/4" NPT	4.5 mm	L078833-000
1/4" NPT	6 mm	L078836-000
1/2" NPT	6 mm	L078938-000

Electrical connection accessories:



Connector	Code
K standard female connector	L12548K-000
K duplex standard female connector	L12544K-000

Extension cable	Code
K thermocouple, standard female connector/naked wire, 2 m long PVC cable	L261K12-200
K duplex thermocouple, standard female connector/naked wire, 2 m long PVC cable	L271K12-200

Other types of electrical connection: see electrical connection

Description:

- Compensation cables for J and K type thermocouples, simple or duplex
- Extension cables for RTD 100 Ω, with 3-wire connection, simple
- PVC coated conductors, with conductive braid and PVC external sheathing. Length: 2 m
- Extension cable terminations
available in: male/female connectors, male connector/naked wire, female connector/naked wire
- Types of connectors
available in: Standard, Miniature, Lemo or Jaeger
Connectors for thermocouples are compensated



Models and codes for ordering

Type of sensing element	Connector	Extension cable terminations		
		Male-female	Male-naked wire	Female-naked wire
K type thermocouple, simple	Standard	L261K14-200	L261K11-200	L261K12-200
	Miniature	L262K14-200	L262K11-200	L262K12-200
K type thermocouple, duplex	Standard	L271K14-200	L271K11-200	L271K12-200
J type thermocouple, simple	Standard	L261J14-200	L261J11-200	L261J12-200
	Miniature	L262J14-200	L262J11-200	L262J12-200
J type thermocouple, duplex	Standard	L271J14-200	L271J11-200	L271J12-200
RTD 100 Ω, simple	Standard		L261311-200	L261312-200
	Jaeger, ref 0429.530		L265311-200	L265312-200
	Lemo size 2 (Ø 6 mm), ref F2M3		L264311-200	L264312-200

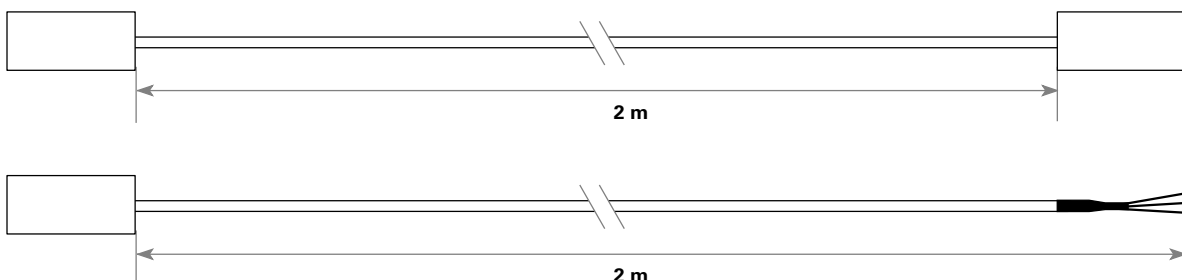

Description:

- J type thermocouple, beaded, in compliance with NF EN 61615 standard
Wire diameter: 1.6 mm
available in: simple (1TC) and duplex (2TCs)
- AISI 316L stainless steel swagged protective tube
available in: L1 and Ø length
- DAN connection head, IP54 protection
■ Pg16 cable gland
- Withstands temperatures up to 600 °C



Models and codes for ordering

TC Qty	L1 (mm)	Ø (mm)	CADID B type
1 xTC	300	17.2	L602103-030
	600		L602103-060
	1000		L602103-100
2 xTC	600	21.3	L602104-060
	1000		L602104-100
	300		L612103-030
2 xTC	600	17.2	L612103-060
	1000		L612103-100
	600		L612104-060
	1000	21.3	L612104-100

CADID B type

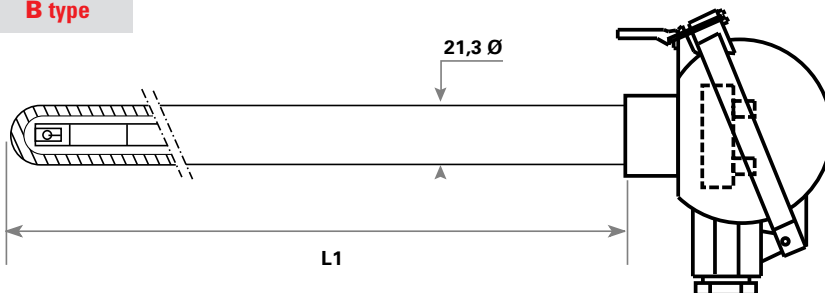

Connection accessories: EBA adjustable flange

Ø	Code
17.2 mm	LU77310-003
21.3 mm	L077311-000

Other types of connection: see connection components

Description:

- K type thermocouple, beaded, in compliance with NF EN 61615 standard
Wire diameter: 2.3 mm
available in: simple (1TC) and duplex (2TC)
- Protective sheathing
available in: length L1 and material: metal or ceramic
 - AISI 310 and AISI 446 steel and Inconel 600 (swagged tubes)
 - ceramic 610 with stainless steel sealing extension
- DAN connection head, IP54 protection
 - Pg16 cable gland
- Operating temperature: 600 °C to 1,200 °C



Models and codes for ordering

TC Qty	L1 (mm)	CADID B type AISI 446 Ø 21.3 mm	CADID B type AISI 310 (AR25-20) Ø 21.3 mm	CADID B type Inconel 600 Ø 21.3 mm	CADID H type Ceramic 610 Ø 15 mm
1 xTC	400	L602406-040	L602409-040	L602427-040	L608417-040
	600	L602406-060	L602409-060	L602427-060	L608417-060
	800	L602406-080	L602409-080	L602427-080	L608417-080
	1000	L602406-100	L602409-100	L602427-100	L608417-100
	1200	L602406-120	L602409-120	L602427-120	L608417-120
2 xTC	400	L612406-040	L612409-040	L612427-040	L618417-040
	600	L612406-060	L612409-060	L612427-060	L618417-060
	800	L612406-080	L612409-080	L612427-080	L618417-080
	1000	L612406-100	L612409-100	L612427-100	L618417-100
	1200	L612406-120	L612409-120	L612427-120	L618417-120

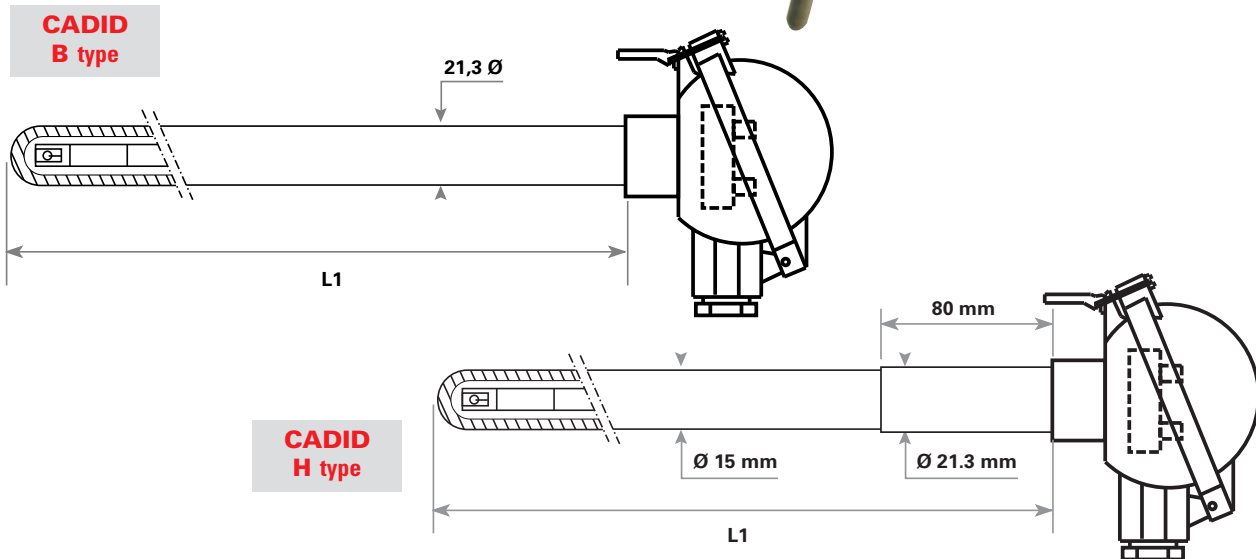

Connection accessories: EBA adjustable flange

Ø	Code
21.3 mm	L077311-000

Other types of connection: see connection components

Description:

- S type thermocouple, beaded, in compliance with NF EN 61615 standard
Wire diameter: 0.5 mm
available in: simple (1TC) and duplex (2TCs)
- Protective sheathing
available in: length L1 and material, metal with internal ceramic sheath or ceramic
 - AISI 310 and AISI 446 steel and Inconel 600 with internal ceramic 610 sheath
 - ceramic 610 with stainless steel sealing extension
- DAN connection head, IP54 protection
 - Pg16 cable gland
- Operating temperature: 600 °C to 1,200°C



Models and codes for ordering

TC Qty	L1 (mm)	CADID C type	CADID C type	CADID C type	CADID H type
		AISI 446 Ø 21.3 mm	AISI 310 (AR25-20) Ø 21.3 mm	Inconel 600 Ø 21.3 mm	Ceramic 610 Ø 15 mm
1 xTC	400	L603706-040	L603709-040	L603727-040	L608717-040
	600	L603706-060	L603709-060	L603727-060	L608717-060
	800	L603706-080	L603709-080	L603727-080	L608717-080
	1000	L603706-100	L603709-100	L603727-100	L608717-100
	1200	L603706-120	L603709-120	L603727-120	L608717-120
2 xTC	400	L613706-040	L613709-040	L613727-040	L618717-040
	600	L613706-060	L613709-060	L613727-060	L618717-060
	800	L613706-080	L613709-080	L613727-080	L618717-080
	1000	L613706-100	L613709-100	L613727-100	L618717-100
	1200	L613706-120	L613709-120	L613727-120	L618717-120

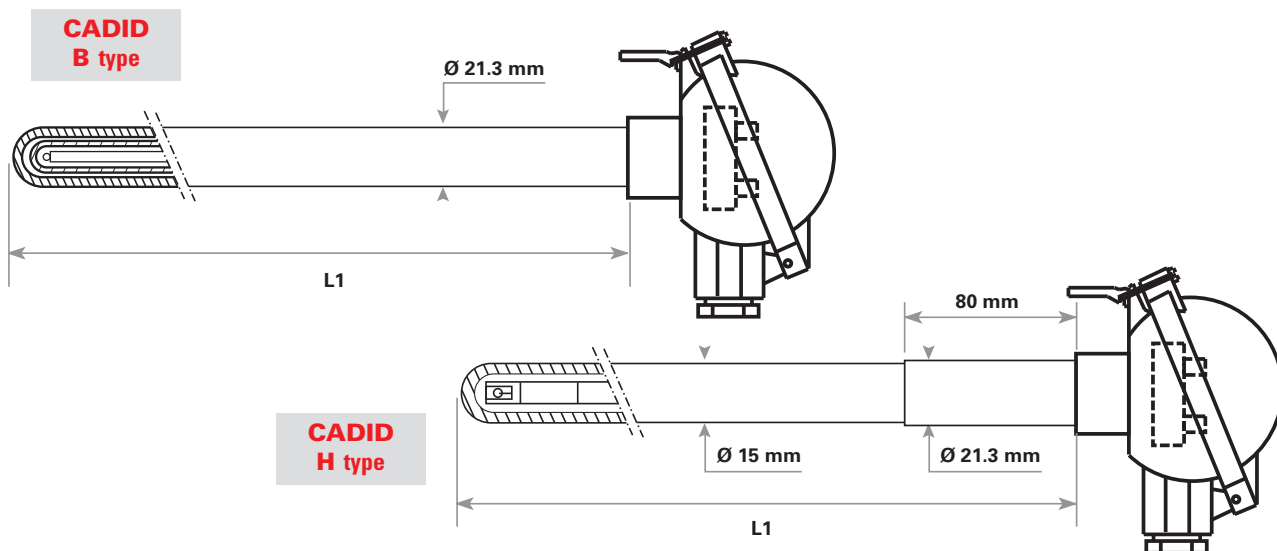

Connection accessories: EBA adjustable flange

Ø	Code
21.3 mm	L077311-000

Other types of connection: see connection components

Description:

- S type thermocouple, beaded, in compliance with NF EN 61615 standard
Wire diameter: 0.5 mm
available in: simple (1TC) and duplex (2TC)
- Ceramic protective sheathing
available in: length L1, simple or double sheath
 - temperatures up to 1,400 °C: 710 alumina simple sheath with stainless steel sealing extension
 - temperatures up to 1,600 °C: ceramic 610 external sheath with 710 alumina internal sheath and stainless steel sealing extension
- DAN or DIN A connection head, IP54 protection
 - Pg16 cable gland



Models and codes for ordering

TC Qty	L1 (mm)	CADID H type - Temperatures up to 1,400 °C 710 alumina sheath - Ø 15 mm Sealing extension Ø = 21.3 mm	CADID J type - Temperatures up to 1,600 °C Double 710 alumina and ceramic 610 sheath - Ø 24 mm Sealing extension - Ø = 32 mm DIN A connection head
		Dan connection head	
1 xTC	600	L608718-060	L609734-060
	1000	L608718-100	L609734-100
	1200	L608718-120	L609734-120
2 xTC	600	L618718-060	L619734-060
	1000	L618718-100	L619734-100
	1200	L618718-120	L619734-120

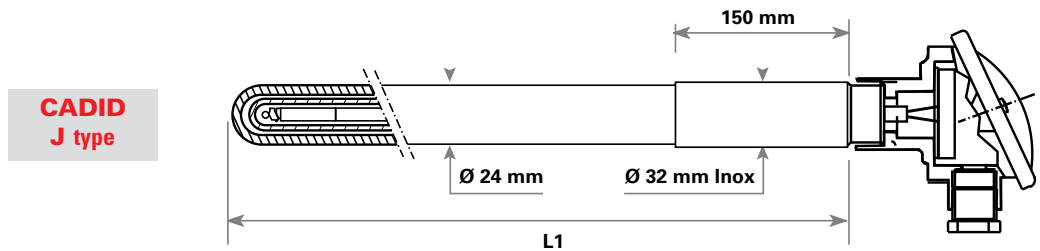
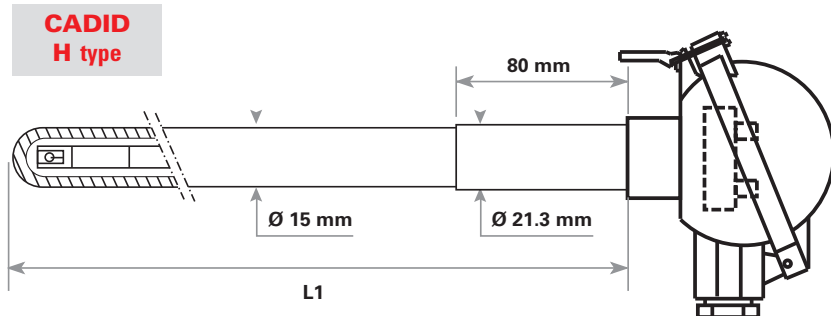

Connection accessories: EBA adjustable flange

Ø	Code
32 mm	L077319-000
21.3 mm	L077311-000

Other types of connection: see connection components

Ambient temperature sensor with cable output

- RTD 100 Ω probe, class A in compliance with NF EN 60751 standard
 - protector: copper-zinc L = 50 mm, Ø 5, M10 x 1.5 connector
 - 3-conductor PVC cable output
 - cable length = 2 metres

Code

L919254-001

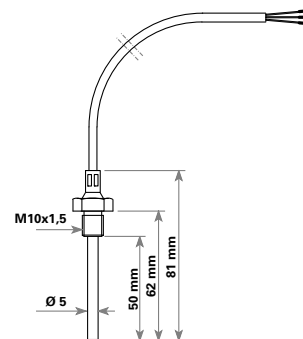

Ambient temperature sensor in wall case

- RTD 100 Ω probe, class A in compliance with NF EN 60751 standard
 - in plastic case
 - 3-wire electrical connection
 - optional 4-20mA transmitter, -30 °C/+70 °C

Optional transmitter	Code
No	L915461-000
Yes	L918856-001

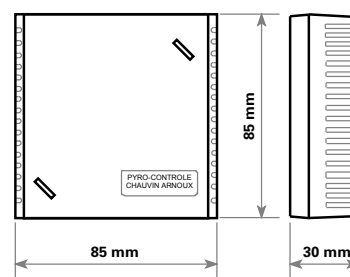

Ambient temperature sensor: IP65 connection head

- RTD 100 Ω probe, class A in compliance with NF EN 60751 standard
 - 316L stainless steel protective sheathing L = 50 mm, Ø 4.5 mm
 - DANV head output, IP65, PE16
 - 3-wire electrical connection
 - wall mounting with stainless steel bracket
 - optional transmitter 4-20mA -30 °C/+70 °C

Optional transmitter	Code
No	L919253-001
Yes	L919253-002

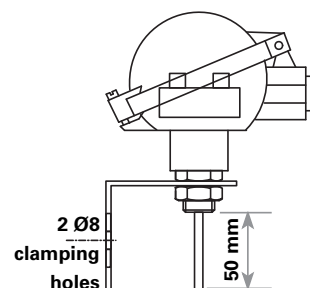

ATEX-II-2-G&D - Explosion-proof ambient temperature sensor

- RTD 100 Ω probe, class A in compliance with NF EN 60751 standard
 - 316L stainless steel protective sheathing L = 50 mm, Ø 4.5 mm
 - PSXV head output, ADF cable gland
 - 3-wire electrical connection
 - wall mounting with stainless steel bracket
 - optional transmitter 4-20mA -30 °C/+70 °C

Optional transmitter	Code
No	L919186-001
Yes	L919186-002

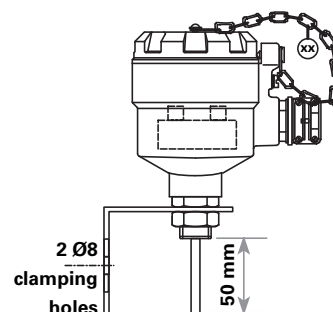

ATEX-II-1-G&D - Intrinsic safety ambient temperature sensor

- RTD 100 Ω probe, class A in compliance with NF EN 60751 standard
 - 316L stainless steel protective sheathing L = 50 mm, Ø 4.5 mm
 - DANVi head output, ADF cable gland
 - 3-wire electrical connection
 - wall mounting with stainless steel bracket
 - Optional transmitter 4-20mA -30 °C/+70 °C

Optional transmitter	Code
No	L919252-001
Yes	L919252-002

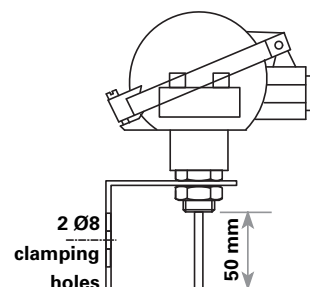

Alumina substrate, attached by gluing, cable output

- RTD 100 Ω probe, class B, 4 wires in compliance with NF EN 60751 standard on alumina substrate
 - mounted by gluing
 - withstands temperatures up to 250 °C
 - PTFE cable output, 2 lengths available

Cable length	Code
2 m	P07604116
5 m	P07604117

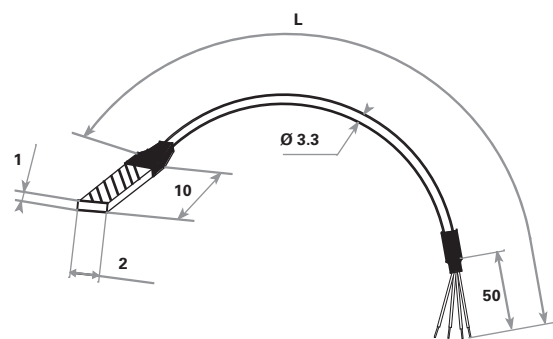

Dural base plate, to be glued or mounted, cable output

- RTD 100 Ω probe, class A, 4 wires in compliance with NF EN 60751 standard on dural base plate
 - mounted by gluing or clamping bolt
 - withstands temperatures up to 200 °C
 - PTFE cable output, 2 lengths available

Cable length	Code
2 m	P07604124
5 m	P07604125

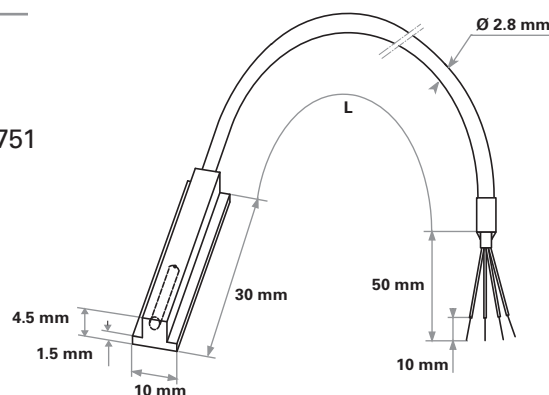

With serflex band, cable output

- RTD 100 Ω probe, class A, 3 wires in compliance with NF EN 60751 standard 316L stainless steel sheathing
 - mounted on tube with serflex band provided with probe
 - withstands temperatures up to 250 °C
 - PTFE cable output, length = 2 metres

Tube diameter (mm)	Code	Tube diameter (mm)	Code
10 < Ø < 15	L918515-001	34 < Ø < 50	L918515-005
16 < Ø < 22	L918515-002	49 < Ø < 65	L918515-006
20 < Ø < 26	L918515-003	64 < Ø < 80	L918515-007
26 < Ø < 34	L918515-004	79 < Ø < 95	L918515-008

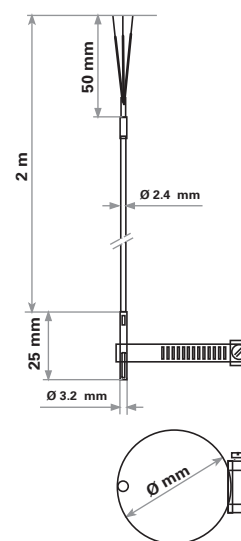

Surface RTD 100 Ω sensing element, attached with adhesive, cable or wire output

- Flat, flexible, RTD 100 Ω sensing element, class B, in compliance with NF EN 60751 standard. Attached with adhesive
 - coating: Silicon-Elastomer
 - output: 1 x 4 wires, silver-plated copper, 0.055 mm² section, PTFE insulated
 - operating temperature: -70 °C to +200 °C

Dimensions (w x L)	Thickness	Code
10 x 23 mm	1.5 mm	L061822-000

- coating: adhesive fiberglass
- output: 2 silver wires
- operating temperature: -80 °C to +250 °C

Dimensions (w x L)	Thickness	Length of Lw wire	Code
20 x 20 mm	0.8 mm	40 mm	L061300-000
12 x 10 mm	0.8 mm	20 mm	L062300-000

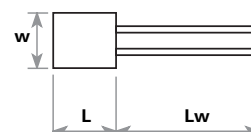
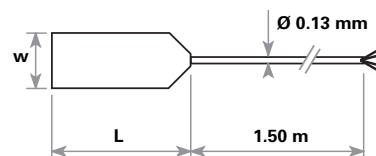

Portable assembly for measurements in aluminium foundries

Description:

- Consisting of a measurement lance with handle and an interchangeable K thermocouple sensing element

To order, select a measurement lance and the K thermocouple sensing element that goes with it. Spare sensing elements are available in packs of 5.

Measurement lance

Description:

- Stainless steel tube with 45° curved termination
- Plastic handle
- Designed for quick fixing of sensing elements with two screws

L (mm)	Code
785	L018900-000
1100	L018906-000
1400	L018904-000

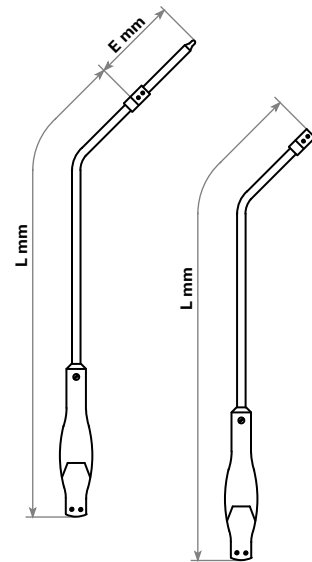

Sensing element

Description:

- K thermocouple in compliance with NF EN 61515 standard
 - 12.7 mm Ø chromite protective sheathing, termination swagged to 6.8 mm Ø
 - Compensation cable output for KTC, insulated with ceramic beads, fiberglass sheathing, terminations equipped with connection lug

E (mm)	For lance L = 785 mm	For lance L = 1100 mm	For lance L = 1400 mm
205	526501A00	526501B00	526501C00
305	526501G00	526501H00	526501J00
510	526502A00	526502B00	526502C00

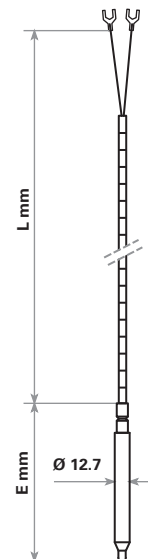

Double slot bayonet	Code
TF5 - J type thermocouple, grounded hot junction on 5 x 30 mm Ø rounded end with double slot bayonet (10.6 mm int. Ø), spring-loaded (5 x 200 mm Ø), 2 m long shielded fiberglass cable output, terminated by connection lug	P01602905
TF5R - J type thermocouple, grounded hot junction on 5 Ø rounded end swagged to 2.5 on 12 mm, with double slot bayonet (10.6 mm int. Ø), spring-loaded (5 x 200 mm Ø), 2 m long shielded fiberglass cable output, terminated by connection lug	P01602906
TF6 - J type thermocouple, grounded hot junction on 6x30 mm Ø rounded end, with double slot bayonet (10.6 mm int. Ø), spring-loaded (6 x 200 mm Ø), 2 m long shielded fiberglass cable output, terminated by connection lug	P01602907
TF16 - J type thermocouple, grounded hot junction on 8 x 12 mm Ø conical end with double slot bayonet (12.5 mm int. Ø), spring-loaded (7 x 200 mm Ø), 2 m long shielded fiberglass cable output, terminated by connection lug	P01602901
TF16D6 - J type thermocouple, grounded hot junction on 6 x 12 mm Ø conical end with double slot bayonet (12.5 mm int. Ø), spring-loaded (6 x 200 mm Ø), 2 m long shielded fiberglass cable output, terminated by connection lug	P01602902
TF4 - J type thermocouple, grounded hot junction on 8 x 12 mm Ø conical end with double slot bayonet (15.5 mm int. Ø), spring-loaded (7 x 200 mm Ø), 2 m long shielded fiberglass cable output, terminated by connection lug	P01602904
TF4D6 - J type thermocouple, grounded hot junction on 6 x 12 mm Ø conical end with double slot bayonet (15.5 mm int. Ø), spring-loaded (6 x 200 mm Ø), 2 m long shielded fiberglass cable output, terminated by connection lug	P01602903



Elbowed, with rotating connector	Code
TF12 - J type thermocouple, grounded hot junction on 6 mm Ø rounded end, 32 mm sleeve, 30 mm plunge, 60 mm neck, M8 x 100 threaded connection, 2 m long shielded fiberglass cable output, terminated by connection lug	P01602908

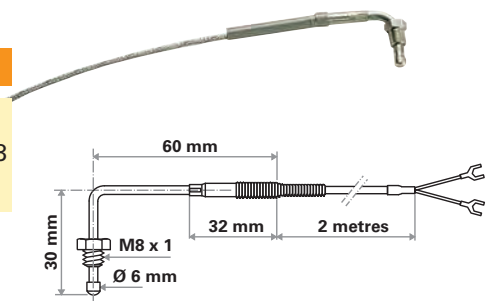

Circular base plate, for flat surface	Code
TF13 - J type thermocouple, non-insulated hot junction, 30° inclination, h 10 x 14 mm Ø base plate, 4.2 mm int. Ø, 2 m long shielded fiberglass cable output, terminated by spade lug	P01602910
TF13 - J type thermocouple, non-insulated hot junction, 60° inclination, h 10 x 14 mm Ø base plate, 4.2 mm int. Ø, 2 m long shielded fiberglass cable output, terminated by spade lug	P01602911

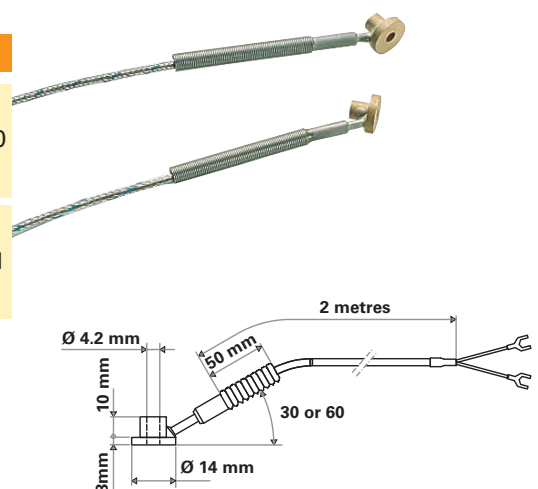

Connection accessories: bayonet connection

see p. 60

Description:

- J and K type thermocouple, sheathed, in compliance with NF EN 61615 standard
Insulated hot junction
available in: simple (1 TC) and duplex (2 TC)
- 304L stainless steel protective sheathing for J type,
Inconel 600 protective sheathing for K type
available in: L1 length and Ø
- naked wire output, 45 mm long
- Withstands temperatures up to 750 °C for J type
and up to 1,100°C for K type
Heat resistance decreases with diameter (*see p. 6*)



Models and codes for ordering

TC Qty	TC type	L1 (mm)	TCG1 Model								
			Ø 1 mm	Ø 1.5 mm	Ø 2 mm	Ø 3 mm	Ø 4,5 mm	Ø 6 mm	Ø 8 mm		
1 TC	J 304L sheathed	262	L220122-009	L220123-009	L220124-009	L220125-009	L220126-009	L220127-009	L220128-009		
		512	L220122-014	L220123-014	L220124-014	L220125-014	L220126-014	L220127-014	L220128-014		
		1012	L220122-024	L220123-024	L220124-024	L220125-024	L220126-024	L220127-024	L220128-024		
		2012	L220122-034	L220123-034	L220124-034	L220125-034	L220126-034	L220127-034			
		3012	L220122-038	L220123-038	L220124-038	L220125-038	L220126-038	L220127-038			
		262	L220152-009	L220153-009	L220154-009	L220155-009	L220156-009	L220157-009	L220158-009		
	K Inconel 600 sheathed	512	L220152-014	L220153-014	L220154-014	L220155-014	L220156-014	L220157-014	L220158-014		
		612	L220152-016	L220153-016	L220154-016	L220155-016	L220156-016	L220157-016	L220158-016		
		812	L220152-020	L220153-020	L220154-020	L220155-020	L220156-020	L220157-020	L220158-020		
		1012	L220152-024	L220153-024	L220154-024	L220155-024	L220156-024	L220157-024	L220158-024		
		2012	L220152-034	L220153-034	L220154-034	L220155-034	L220156-034	L220157-034			
		3012	L220152-038	L220153-038	L220154-038	L220155-038	L220156-038	L220157-038			
		2 TC	J 304L sheathed	262			L220134-009	L220135-009	L220136-009	L220137-009	L220138-009
				512			L220134-014	L220135-014	L220136-014	L220137-014	L220138-014
1012					L220134-024	L220135-024	L220136-024	L220137-024	L220138-024		
2012					L220134-034	L220135-034	L220136-034	L220137-034			
3012					L220134-038	L220135-038	L220136-038	L220137-038			
K Inconel 600 sheathed	262					L220164-009	L220165-009	L220166-009	L220167-009	L220168-009	
	512					L220164-014	L220165-014	L220166-014	L220167-014	L220168-014	
	1012					L220164-024	L220165-024	L220166-024	L220167-024	L220168-024	
	2012					L220164-034	L220165-034	L220166-034	L220167-034		
	3012					L220164-038	L220165-038	L220166-038	L220167-038		

Description:

- J and K type thermocouple, in compliance with NF EN 61615 standard Simple (1 TC)
- Naked wires, straight, welded
available in: L length and Ø
- Withstands temperatures up to 750 °C for J type and up to 1,100 °C for K type



Models and codes for ordering

TC Qty	L1* (mm)	L1 (mm)	J type 1.6 mm Ø wire	K type 2.3 mm Ø wire	K type 3 mm Ø wire
1 x TC	300	380	L201214-038		
	400	480		L201415-048	L201417-048
	600	680	L201214-068	L201415-068	L201417-068
	800	880		L201415-088	L201417-088
	1000	1080	L201214-108	L201415-108	L201417-108
	1200	1280		L201415-128	L201417-128

(*): L1 (mm) corresponds to the length under head of the beaded thermocouple assemblies in this catalogue.

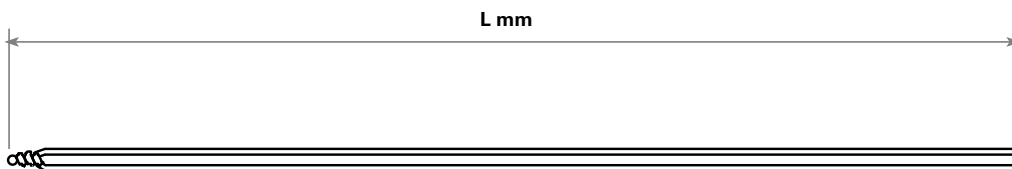

Description:

- J and K type thermocouple, beaded, in compliance with NF EN 61615 standard
available in: simple (1 TC) and duplex (2TC)
- Beaded thermocouple wires protected by ceramic 610 insulators
available in: L length and \emptyset
- Withstands temperatures up to 750 °C for J type and up to 1,100 °C for K type



Models and codes for ordering

TC type	L1* (mm)	L1 (mm)	0.51 mm \emptyset Wire		1.6 mm \emptyset wire	
			Simple thermocouple insulator \emptyset 3 mm	Duplex thermocouple insulator \emptyset 5.5 mm	Simple thermocouple insulator \emptyset 7 mm	Duplex thermocouple insulator \emptyset 9 mm
J	300	380	L202211-038	L202221-038	L202214-038	L202224-038
	400	480	L202211-068	L202221-068	L202214-068	L202224-068
	600	680	L202211-108	L202221-108	L202214-108	L202224-108

TC type	L1* (mm)	L1 (mm)	0.51 mm \emptyset Wire		2.3 mm \emptyset wire	
			Simple thermocouple insulator \emptyset 3 mm	Duplex thermocouple insulator \emptyset 5.5 mm	Simple thermocouple insulator \emptyset 10 mm	Duplex thermocouple insulator \emptyset 12 mm
K	400	480	L202411-048	L202421-048	L202415-048	L202425-048
	600	680	L202411-068	L202421-068	L202415-068	L202425-068
	800	880	L202411-088	L202421-088	L202415-088	L202425-088
	1000	1080	L202411-108	L202421-108	L202415-108	L202425-108
	1200	1280	L202411-128	L202421-128	L202415-128	L202425-128

(*): L1 (mm) corresponds to the length under head of the beaded thermocouple assemblies in this catalogue.

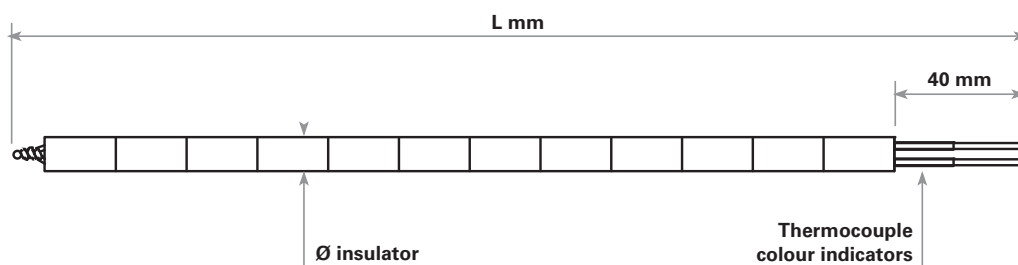

Description:

- J and K type thermocouple, in compliance with NF EN 61615 standard
available in: simple (1 TC) and duplex (2TC)
- Welded fiberglass insulated thermocouple wires
available in: L length and Ø
- Withstands temperatures up to 300 °C



Models and codes for ordering

TC type	L1* (mm)	L1 (mm)	Simple thermocouple		Duplex thermocouple
			Wire Ø 0.5 mm	Wire 7 x Ø 0.2 mm Stainless steel braid	Wire 7 x Ø 0.2 mm Stainless steel braid
J	400	480	L203211-048	L203212-048	L203222-048
	600	680	L203211-068	L203212-068	L203222-068
	800	880	L203211-088	L203212-088	L203222-088
	1000	1080	L203211-108	L203212-108	L203222-108
	1200	1280	L203211-128	L203212-128	L203222-128

TC type	L1* (mm)	L1 (mm)	Simple thermocouple		Duplex thermocouple
			Wire Ø 0.6 mm	Wire 7 x Ø 0.2 mm Stainless steel braid	Wire 3 x Ø 0.3 mm Stainless steel braid
K	400	480	L203411-048	L203412-048	L203422-048
	600	680	L203411-068	L203412-068	L203422-068
	800	880	L203411-088	L203412-088	L203422-088
	1000	1080	L203411-108	L203412-108	L203422-108
	1200	1280	L203411-128	L203412-128	L203422-128

(*): L1(mm) corresponds to the length under head of the beaded thermocouple assemblies in this catalogue.

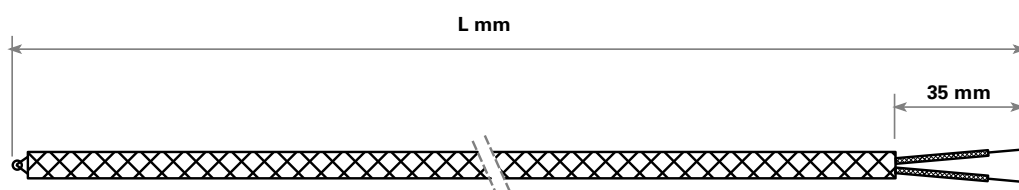

RTD 100 Ω thermometer

Description:

- 1 input via miniature 3-pin female connector
- -50 °C to +200 °C measurement range; choice of °C or F
- ± 0.5 °C accuracy; 0 resolution, 1 °C
- 2,000-pixel backlit display
- Memorisation of maximum value; "Hold" function
- Comes with shockproof protective cover

Details for ordering	Code
C.A 865 RTD 100 Ω thermometer	P01.6503.01Z



Accessories and codes for ordering

Designation	Utilisation	Code
SP10 sensor	Surface temperature	P03652712
SP11 sensor	Needle	P03652713
SP12 sensor	Ambient temperature	P03652714
SP13 sensor	Liquid	P03652715



Infrared thermometer and K thermocouple

Description:

- 2,000-pixel back-lit display
- Comes with shockproof protective cover

Infrared measurement, laser sighting

- -20 °C to +550 °C measurement range; choice of °C or F
- ± 2 % reading accuracy or 3 °C; 1°C Resolution
- Targeting range: $D/\varnothing = 10/1$
- Adjustable emissivity from 0.1 to 1
- 1 s response time
- High and low sound alarms
- Memorisation of maximum and minimum values

Measurement with K couple

- 1 K thermocouple input via miniature female connector
- -40 °C to +1,350 °C measurement range; choice of °C or F
- ± 0.1% reading accuracy ±1 °C; 1 °C or 0.1 °C Resolution

Details for ordering	Code
Infrared thermometer C.A 876	P01.6514.03Z



K thermocouple thermometers

Description:

- **1 K thermocouple input via miniature female connector:
C.A 861 model**
 - -40 °C to +1,350 °C measurement range; choice of °C or F
 - ± 0.1 % reading accuracy ±1 °C
 - Choice of resolution: 0.1 °C to 1 °C
 - 2,000-pixel backlit display
 - Memorisation of maximum value and "Hold" function
 - Comes with shockproof protective cover
- **2 K thermocouple inputs via miniature female connectors:
C.A 863 model**
 - -50 °C to +1,300 °C measurement range; choice of °C or F
 - ΔT differential temperature measurement
 - ± 0.3% reading accuracy ±1 °C from -50 °C to +1,000 °C and ± 0.5 % for higher temperatures
 - Choice of resolution: 0.1 °C or 1 °C
 - 2,000-pixel backlit display
 - "Hold" function and memorisation of maximum value
 - Comes with protective shockproof cover

Details for ordering	Code
K thermocouple thermometer, 1 input C.A 861	P01.6501.01Z
K thermocouple thermometer, 2 inputs C.A 863	P01.6502.01Z



Accessories and codes for ordering

Designation	Utilisation	Code
SK1 sensor	Needle	P03652901
SK2 sensor	Flexible, general use	P03652902
SK3 sensor	Semi-rigide, general use	P03652903
SK4 sensor	Surface temperature	P03652904
SK5 sensor	Surface temperature	P03652905
SK6 sensor	Flexible, general use	P03652906
SK7 sensor	Ambient temperature	P03652907
SK8 sensor	Surface temperature, auto-grip	P03652908
SK11 sensor	Needle	P03652917
SK13 sensor	General use	P03652918
SK14 sensor	Surface temperature	P03652919
SK15 sensor	Surface temperature	P03652920
SK17 sensor	Ambient temperature	P03652921
SK19 sensor	Surface temperature, magnet	P03652922
918400 sensor	For tapping, specially for pneumatics	L918400-000
CK1 extension	lg 1 m for TCK	P03652909
CK2 extension	lg 1 m for TCK	P03652910
CK3 extension	lg 1 m for TCK	P03652913
CK4 extension	lg 1 m for TCK	P03652914
PP1 handle		P03652912



SK sensors

Connection heads

Models and codes for ordering

Type	Material	Process connection	Cable primary	Protection	Terminal block	Code
MA	Alu	M10	PE9	IP54	BM04	L015001-000
PM	Thermoset	G1/2	PE11	IP54	2 terminals	L125101-000
		G1/2	PE11	IP54	4 terminals	L125102-000
		G1/2	PE11	IP54	3 terminals	L125103-000
DAN	Alu	G1/2	PE16	IP54	BB type	L015013-000
DCM	Alu	G1/2	PE16	IP54	BB type	L015017-000
DIN B	Alu	G1/2	PE16	IP54	BB type	L015010-000
		M24 x 1.5	PE16	IP54	BB type	L015019-000
NS	Noryl	G1/2	PE16	IP54	BB type	L015027-000
PBK	PVC	M24 x 1.5	PE16	IP54	BB type	L015030-000
KST	Stainless steel	G1/2	M20x1.5	IP67	BB type	L015035-000
DIN A	Alu	G1/2	PE16	IP54	BA type	L015020-000
		G3/4	PE16	IP54	BA type	L015021-000
		Ø 22.3	PE16	IP54	BA type	L015023-000
KNE	Alu with epoxy finish	G1/2	M20x1.5	IP67	BB type	L015042-000
PSXV 1 input	Alu	G1/2	3/4NPT	For ATEX-compliant assembly. Regulated sales	BB type	L124300-000
	Alu with epoxy finish	G1/2	3/4NPT		BB type	L124300-001
	Stainless steel	G1/2	3/4NPT		BB type	L124400-000
PSXV 2 inputs	Alu with epoxy finish	G1/2	2 x 3/4NPT		BB type	L124320-001



MA



PM



DAN



DCM



DIN B



NS



PBK



KST



DIN A



KNE



PSXV

Cable glands

Models and codes for ordering

Type	Material	Feedthrough Qty	Fastening	Ø of primary cable	Protection	Code
PE9	Nickel-plated brass	1	Yes	5 to 9.5	None	L017211-000
PE11	Nickel-plated brass	1	No	6.5 to 10.5	None	L017113-000
	Polycarbonate	1	No	7 to 10	None	L017385-000
PE16	Nickel-plated brass	2	No	6 to 8	None	L017208-000
1/2" NPT	Nickel-plated brass	1	No	4 to 8	None	L017128-000
		1	Yes	4 to 8	None	L017225-000
1/2" NPT	Alu	1	Yes	2 to 9	ATEX "d"	L017395-000
3/4" NPT	Alu	1	Yes	7 to 12	ATEX "d"	L017396-000

Terminal blocks

Models and codes for ordering

Type	Head type	Sensor type	Terminal Qty	S/S: screw-on/screw-on S/W: screw-on/welded	Code
BM04	MA	RTD 100 /TC	4	S/S	L015007-000
BB02	DIN	RTD 100 /TC	2	S/S	L015015-000
BA02	DIN A	TC	2	S/S	L015054-000
BB12	DIN	RTD 100 /TC	2	S/W	L015055-000
BB13	DIN	RTD 100 /TC	3	S/W	L015060-000
BB04	DIN	RTD 100 /TC	4	S/S	L015062-000
BA04	DIN A	TC	4	S/S	L015065-000

Connectors for RTD 100 Ω

- For RTD 100 Ω probes, 3-wire assembly
- Withstands temperatures from -50 °C to +210 °C
- Optional cable fastener for miniature and standard connectors



Models and codes for ordering

male or female	Type	Pin Qty	Dimensions L x w x h	Code
Male	Standard	3	35 x 25 x 12.5	L018290-000
Female				L018211-004
Cable fastener for standard 3-pin connector				L018250-017
Male	Miniature	3	19 x 24 x 8	L018280-000
Female				L018200-005
Cable fastener for standard 3-pin connector				L018200-006

Compensated connectors for thermocouples



Models and codes for ordering

Male or female	Simple and duplex	Size	Section	Type of thermocouple					
				J type	K type	T type	N type	S type	Cu-Cu B type
Male	Simple	Standard	Rectangle	L12547J-000	L12547K-000	L12547T-000	L12547N-000	L12547S-000	L12547C-000
		Miniature	Rectangle	L12587J-000	L12587K-000	L12587T-000	L12587N-000	L12587S-000	L12587C-000
Female	Simple	Standard	Rectangle	L12543J-000	L12543K-000	L12543T-000	L12543N-000	L12543S-000	L12543C-000
		Miniature	Rectangle	L12548J-000	L12548K-000	L12548T-000	L12548N-000	L12548S-000	L12548C-000
Female socket for panel	Simple	Standard	Rectangle	L12544J-000	L12544K-000	L12544T-000	L12544N-000	L12544S-000	L12544C-000
		Standard	Circular	L12545J-000	L12545K-000	-	-	L12545S-000	L12545C-000
Female socket for panel	Simple	Standard	Rectangle	L12588J-000	L12588K-000	L12588T-000	L12588N-000	L12588S-000	L12588C-000
		Miniature	Rectangle	L12585J-000	L12585K-000	L12585T-000	L12585N-000	L12585S-000	L12585C-000
Female socket for panel	Simple	Standard	Rectangle*	L12544J-000	L12544K-000	L12544T-000	L12544N-000	L12544S-000	L12544C-000
		Miniature	Rectangle*	L12584J-000	L12584K-000	L12584T-000	L12584N-000	L12584S-000	L12584C-000

* with two lugs

Connecting strips for thermocouples



Models and codes for ordering

Circuit Qty	Size	J type	K type	T type	S type	Cu-Cu B type
1	Standard	L12549J-000	L12549K-000	L12549T-000	L12549S-000	L12549C-000

Cable Fastener

- For electrical connection of thermocouple wires, extension and compensation cables
- Withstands temperatures from -50 °C to +210 °C
- Colour code in compliance with IEC 584-3 (NFC42324) standard

Models and codes for ordering

Connector type	Simple and duplex	Code
Standard	Simple	L125490-000
Miniature	Simple	L125890-000
Standard	Duplex	L125499-000



Panels for female thermocouple connectors



Models and codes for ordering

Connector type	Circuit Qty	Code
Standard size rectangular face	1	L125401-000
	2	L125402-000
	3	L125403-000
	4	L125404-000
	5	L125405-000
	6	L125406-000
	8	L125408-000
	10	L125410-000
	12	L125412-000
	16	L125416-000
Miniature size rectangular face	1	L125801-000
	2	L125802-000
	3	L125803-000
	4	L125804-000
	5	L125805-000
	6	L125806-000
	8	L125808-000
	10	L125810-000
12	L125812-000	
16	L125816-000	
20	L125820-000	
24	L125824-000	

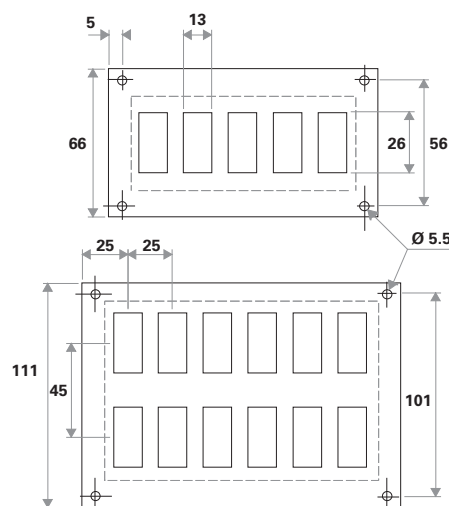

Panels for standard size female thermocouple connectors, rectangular face

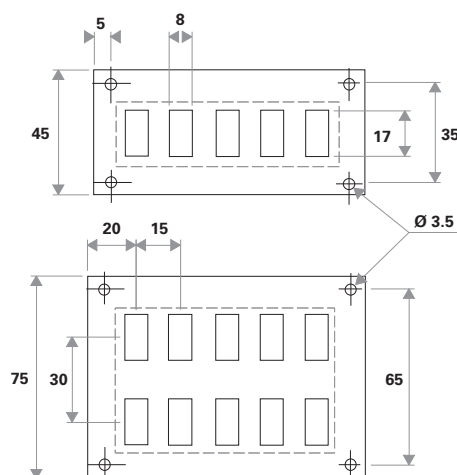

Panels for miniature size female thermocouple connectors, rectangular face

Wound RTD 100 Ω , with cylindrical body

Models and codes for ordering

Type	\varnothing (mm)	Length (mm)	Material of cylindrical body	Tolerance class	Code
RTD 100 Ω	2.7	13	Glass	B	L061141-000
	0.9	15	Ceramic	A	L061404-110
	1.5	8	Ceramic	A	L061410-110
	1.5	15	Ceramic	A	L061406-110
	1.5	15	Ceramic	A/3	L061512-000
	1.5	25	Ceramic	A	L061402-110
	1.5	25	Ceramic	A/2	L061502-120
	2	6	Ceramic	A	L061405-110
	2	6	Ceramic	A/5	L061507-150
	2	15	Ceramic	A	L061407-110
	2.8	15	Ceramic	A	L061409-110
	2.8	25	Ceramic	A	L061401-110
	2.8	25	Ceramic	A/5	L061209-000
2 RTD 100 Ω	4.5	30	Ceramic	A	L061408-110
	2.8	25	Ceramic	A	L062401-110
	4.5	30	Ceramic	A	L062408-110

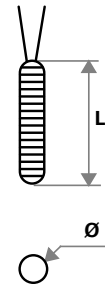

RTD 100 Ω and RTD 1000 Ω with deposited platinum film

Models and codes for ordering

Type	Dimensions L x l	Substrate material	Tolerance class	Code
1 RTD 1000 Ω	10 x 2	Alumina	A	L061307-000
RTD 100 Ω	2.3 x 2		A	L061703-000
	10 x 2		B	L061711-000
	2.3 x 2		1/3 B	L061721-000

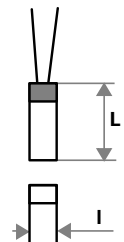

RTD 100 Ω for surface temperatures:

- See page 39

Wires and cables for thermocouples

Models and codes for ordering

Type	Covering	Tolerance class	Wire Ø	External Ø	Packaging	Code		
T type	Naked wire	2	1.5 mm		per metre	L209114-000		
	FEP Insulated		0.2 mm	0.4 mm	coil 25 m	L218101-000		
			0.3 mm	1.1 mm	coil 25 m	L218102-000		
			0.5 mm	1.3 mm	coil 25 m	L218103-000		
			0.2 mm	0.4 mm	coil 100 m	L217101-000		
			0.3 mm	1.1 mm	coil 100 m	L217102-000		
			0.5 mm	1.3 mm	coil 100 m	L217103-000		
	Fiberglass insulated		0.5 mm	1.5 x 2.4	per metre	L219123-000		
J type	Naked wire	2	1.60 mm		per metre	L209214-000		
	FEP Insulated		0.2 mm	0.4 mm	coil 25 m	L218201-000		
					coil 100 m	L217201-000		
			0.3 mm	1.1 mm	coil 25 m	L218202-000		
					coil 100 m	L217202-000		
			0.5 mm	1.3 mm	coil 25 m	L218203-000		
					coil 100 m	L217203-000		
	Fiberglass insulated		0.5 mm	1.5 x 2.4	per metre	L219223-000		
			0.8 mm	2 x 3	per metre	L219225-000		
			7 x 0.2 mm	1.4 x 2.2	per metre	L219228-000		
			1 mm	2.7 x 4.2	per metre	L219246-000		
			Fiberglass insulated with stainless steel braid	7 x 0.2 mm	3	per metre	L219237-000	
		7 x 0.2 mm	2.2 x 3.2	per metre	L219238-000			
K type	Naked wire	1	0.51 mm		per metre	L209409-000		
			0.60 mm		per metre	L209410-000		
			1.02 mm		per metre	L209412-000		
			1.62 mm		per metre	L209414-000		
			2.3 mm		per metre	L209415-000		
			2.9 mm		per metre	L209417-000		
	FEP Insulated	2	0.2 mm	0.4 mm	coil 25 m	L218401-000		
					coil 100 m	L217401-000		
			0.3 mm	1.1 mm	coil 25 m	L218402-000		
					coil 100 m	L217402-000		
			0.5 mm	1.3 mm	coil 25 m	L218403-000		
					coil 100 m	L217403-000		
	Fiberglass insulated	1	0.51 mm	1.02 mm	per metre	L219413-000		
			0.25 mm	0.9 x 1.3	per metre	L219421-000		
			0.3 mm	1.1 x 1.8	per metre	L219422-000		
			0.5 mm	1.3 x 2.2	per metre	L219423-002		
			0.6 mm	1.6 x 2.6	per metre	L219424-000		
			1 mm	2.7 x 4.2	per metre	L219446-000		
			Fiberglass insulated with stainless steel braid	1	7 x 0.2 mm	2.3 x 3.2	per metre	L219438-000
			Ceramic covered	1	0.8 mm	2.4 x 4.0	per metre	L219465-000
S type	Naked wire	2	0.35 mm		per metre	L209608-000		
	Naked wire		0.50 mm		per metre	L209609-000		
R type	Naked wire	2	0.50 mm		per metre	L209709-000		
W/Re type	Naked wire		0.50 mm		per metre	L209909-000		

Thermocouple extension and compensation wires and cables

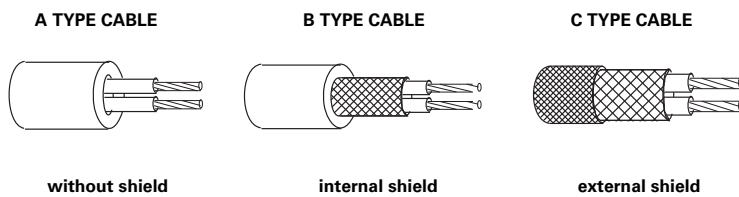

Models and codes for ordering

TC type	TC Qty	External sheath	ext. Ø mm	X/C (1)	Class (2)	pack. Ø	Cable type	Per metre	50 m coil	100 m coil	250 m coil		
T	1TC	PVC	4	X	1	3 x 0.3	B	L929101-120	L921101-120	L922101-120	L923101-120		
J	1TC	PVC	4	X	1	3 x 0.3	B	L929201-120	L921201-120	L922201-120	L923201-120		
			5	X	2	7 x 0.3	B	L929215-120	L921215-120	L922215-120	L923215-120		
			7	X	2	14 x 0.3	B	L929214-110	L921214-110	L922214-110	L923214-110		
			7.5	X	2	19 x 0.3	A	L929208-110	L921208-110	L922208-110	L923208-110		
		7.8	X	2	19 x 0.3	B	L929203-110	L921203-110	L922203-110	L923203-110			
		Silicone	5	X	1	7 x 0.3	B	L929206-120	L921206-120	L922206-120	L923206-120		
		FEP	3.5	X	1	7 x 0.2	B	L929210-120	L921210-120	L922210-120	L923210-120		
		FG (3)	4 x 6	X	1	19 x 0.3	C	L929209-120	L921209-120	L922209-120	L923209-120		
			4 x 6	X	1	14 x 0.3	C	L929218-120	L921218-120	L922218-120	L923218-120		
	2TC	PVC	5	X	1	3 x 0.3	B	L929301-120	L921301-120	L922301-120	L923301-120		
K	1TC	PVC	4	X	1	3 x 0.3	B	L929401-120	L921401-120	L922401-120	L923401-120		
			5	C	2	7 x 0.3	B	L929515-110	L921515-110	L922515-110	L923515-110		
			7	C	2	14 x 0.3	B	L929514-110	L921514-110	L922514-110	L923514-110		
			7.5	C	2	19 x 0.3	A	L929408-110	L921408-110	L922408-110	L923408-110		
		7.8	C	2	19 x 0.3	B	L929403-110	L921403-110	L922403-110	L923403-110			
		Silicone	4.2	X	1	7 x 0.2	B	L929416-120	L921416-120	L922416-120	L923416-120		
		FEP	5	X	1	7 x 0.3	B	L929406-120	L921406-120	L922406-120	L923406-120		
			3.5	X	1	7 x 0.2	B	L929410-120	L921410-120	L922410-120	L923410-120		
		FG (3)	4 x 6	C	2	19 x 0.3	C	L929409-110	L921409-110	L922409-110	L923409-110		
					4 x 6	X	1	14 x 0.3	C	L929417-120	L921417-120	L922417-120	L923417-120
					4 x 6	X	1	14 x 0.3	C	L929418-120	L921418-120	L922418-120	L923418-120
			2TC	PVC	5	C	2	3 x 0.3	B	L929701-110	L921701-110	L922701-110	L923701-110
S	1TC	PVC	4	C	2	3 x 0.3	B	L929601-110	L921601-110	L922601-110	L923601-110		
			5	C	2	7 x 0.3	B	L929615-110	L921615-110	L922615-110	L923615-110		
			7.5	C	2	19 x 0.3	A	L929608-110	L921608-110	L922608-110	L923608-110		
			7.8	C	2	19 x 0.3	B	L929603-110	L921603-110	L922603-110	L923603-110		
		Silicone	5	C	2	7 x 0.3	B	L929606-110	L921606-110	L922606-110	L923606-110		
		FEP	3.5	C	2	7 x 0.2	B	L929610-110	L921610-110	L922610-110	L923610-110		
		FG (3)	4 x 6	C	2	19 x 0.3	C	L929609-110	L921609-110	L922609-110	L923609-110		
B	1TC	FEP	3.5	C	2	7 x 0.2	B	L929620-110	L921620-110	L922620-110	L923620-110		
N	1TC	PVC	4	X	1	3 x 0.3	B	L929901-110	L921901-110	L922901-110	L923901-110		
		FEP	3.5	X	1	7 x 0.2	B	L929910-120	L921910-120	L922910-120	L923910-120		
		FG (3)	4x6	X	1	14 x 0.3	C	L929919-120	L921919-120	L922919-120	L923919-120		

(1) - X: extension cable - C: compensation cable
 (2) - Class: tolerance class in compliance with IEC 584
 (3) - FG: fiberglass

Extension wires and cables for RTD 100 Ω

Models and codes for ordering

Wire and cable	Metal	Wire Qty	External sheath	External Ø	Wire Ø	Conductor insulation	Internal braid	External braid	Code per meter
Wire	Ag	1			0.5 mm	None			L063105-000
	Ni	1			0.5 mm	None			L063205-000
	Ag	1		1.1 mm	0.5 mm	Fiberglass			L063404-000
Cable	Cu	2	Silicone	4.6 mm	16 x 0.2 mm	Silicone	None		L067824-000
		3	PVC	4.2 mm	7 x 0.2 mm	PVC	Tinned Cu		L067803-000
			PVC	3.7 mm	7 x 0.2 mm	PVC	None		L067810-000
			Silicone	4.6 mm	7 x 0.2 mm	PVC	None		L067805-000
			FEP	2.1 mm	7 x 0.06 mm	FEP	Silver-plated Cu		L067813-000
			Fiberglass	3.5 mm	7 x 0.2 mm	Fiberglass	None	Stainless steel	L067836-000
		4	PVC	5.0 mm	7 x 0.2 mm	PVC	Tinned Cu		L067804-000
FEP	3.3 mm		7 x 0.2 mm	FEP	Silver-plated Cu		L067815-000		

Insulation

Models and codes for ordering

Material	External Ø	Hole Qty	Feedthrough Ø	Length	Code
Ceramic 610	3.0 mm	2	0.8 mm	25 mm	L031213-000
	4.5 mm	2	0.7 mm	200 mm	L031227-000
	5.5 mm	2	1.8 mm	25 mm	L031234-000
	7.0 mm	2	2.1 mm	25 mm	L031243-000
	10.0 mm	2	3.5 mm	25 mm	L031258-000
	10.0 mm	2	3.5 mm	50 mm	L031259-000
	12.0 mm	2	4 mm	25 mm	L031273-000
	L12x8	2	4.0 mm	5 mm	L031321-000
	4.5 mm	4	1.0 mm	400 mm	L031428-000
	5.5 mm	4	1.2 mm	25 mm	L031443-000
	9.0 mm	4	2.8 mm	25 mm	L031463-000
	12.0 mm	4	3.5 mm	5 mm	L031471-000
	Hot junction insulation	7.0 mm	2	4.0 mm	30 mm
12.0 mm		2	4.0 mm	40 mm	L031524-000
710 Alumina	2.0 mm	1	1.2 mm	50 mm	L032124-000
	1.2 mm	2	0.35 mm	250 mm	L032216-000
	2.8 mm	2	0.8 mm	50 mm	L032234-000
	2.5 mm	2	0.7 mm	250 mm	L032236-000
	3.0 mm	2	0.8 mm	250 mm	L032260-000
	3.0 mm	2	0.8 mm	1600 mm	L032262-000
	4.0 mm	2	1.2 mm	1000 mm	L032266-000
	4.0 mm	2	1 mm	25 mm	L032270-000
	1.55 mm	2	0.4 mm	250 mm	L032276-000
	6.0 mm	2	1.8 mm	1000 mm	L032291-000
	2.8 mm	4	0.7 mm	250 mm	L032446-000
	4.0 mm	4	1.2 mm	1000 mm	L032471-000
	4.0 mm	6	0.8 mm	1100 mm	L032481-000

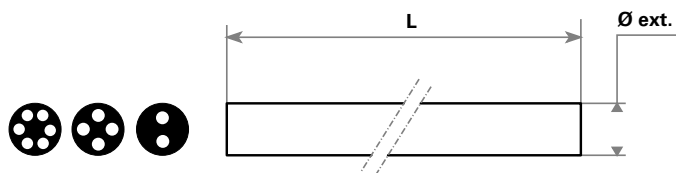

Ceramic sheath

Models and codes for ordering

Material	External Ø	Thickness	Length	Code
Ceramic 610	7 mm	1 mm	1000 mm	L041950-000
	10 mm	1.5 mm	530 mm	L041303-000
	10 mm	1.5 mm	1030 mm	L041310-000
	12 mm	2 mm	1000 mm	L041333-000
	15 mm	2 mm	530 mm	L041622-000
	15 mm	2 mm	740 mm	L041629-000
	15 mm	2 mm	1030 mm	L041633-000
	15 mm	2 mm	2030 mm	L041645-000
	17 mm	2 mm	1030 mm	L041648-000
	20 mm	2.5 mm	1100 mm	L041700-000
24 mm	2.5 mm	1430 mm	L041940-000	
Ceramic 530	26 mm	4 mm	1030 mm	L042900-000
	26 mm	4 mm	1430 mm	L042901-000
	34 mm	4 mm	1500 mm	L042841-000
	26 mm	4 mm	530 mm	L042905-000
710 Alumina	8 mm	1.5 mm	800 mm	L043048-000
	8 mm	1.5 mm	1000 mm	L043058-000
	8 mm	1.5 mm	1200 mm	L043062-000
	6 mm	1 mm	1200 mm	L043101-000
	7 mm	1.5 mm	400 mm	L043118-000
	7 mm	1.5 mm	600 mm	L043124-000
	7 mm	1.5 mm	800 mm	L043130-000
	7 mm	1.5 mm	1000 mm	L043135-000
	7 mm	1.5 mm	1200 mm	L043192-000
	10 mm	2 mm	530 mm	L043222-000
	10 mm	2 mm	740 mm	L043227-000
	10 mm	2 mm	1030 mm	L043235-000
	12 mm	2 mm	600 mm	L043324-000
	12 mm	2 mm	800 mm	L043330-000
	12 mm	2 mm	900 mm	L043332-000
	15 mm	2.5 mm	740 mm	L043427-000
	15 mm	2.5 mm	1030 mm	L043435-000
	20 mm	2.5 mm	800 mm	L043630-000
	20 mm	2.5 mm	1000 mm	L043633-000
	20 mm	2.5 mm	1030 mm	L043638-000
24 mm	2.5 mm	740 mm	L043722-000	
Metal-Ceramic	22 mm	3 mm	229 mm	L044500-000
	22 mm	3 mm	457 mm	L044502-000
	22 mm	3 mm	610 mm	L044504-000
	22 mm	3 mm	762 mm	L044506-000
	22 mm	3 mm	914 mm	L044508-000
	22 mm	3 mm	1219 mm	L044512-000
Cryston	25 mm	6.5 mm	500 mm	L044430-000
	25 mm	6.5 mm	700 mm	L044434-000
Sialon	16 mm	8 mm	450 mm	L044202-000
Silicon carbide	50 mm	17.5 mm	305 mm	L044532-000
	50 mm	17.5 mm	406 mm	L044536-000
	50 mm	17.5 mm	458 mm	L044537-000
	50 mm	17.5 mm	610 mm	L044539-000
	50 mm	17.5 mm	1070 mm	L044545-000
	50 mm	17.5 mm	1220 mm	L044547-000

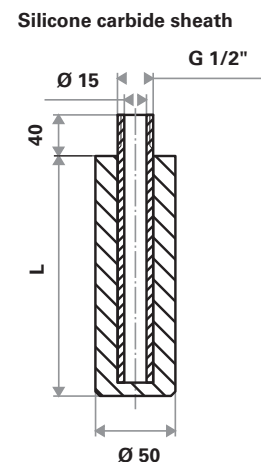
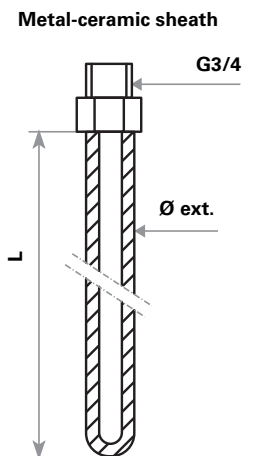
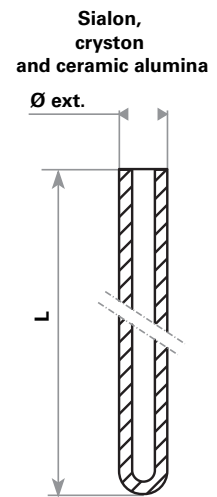

Swagged metallic tubes

Models and codes for ordering

Material	External Ø	Thickness	Length	Code
316L	21 mm	3 mm	500 mm	L050320-000
			500 mm	L052320-000
Aisi 446	21 mm	3 mm	600 mm	L052324-000
			1000 mm	L052333-000
Inconel 600	21 mm	3 mm	500 mm	L053320-000
			800 mm	L053330-000
AR 25/20	21 mm	3 mm	1000 mm	L053333-000
			400 mm	L054318-000
			800 mm	L054330-000
			1000 mm	L054333-000

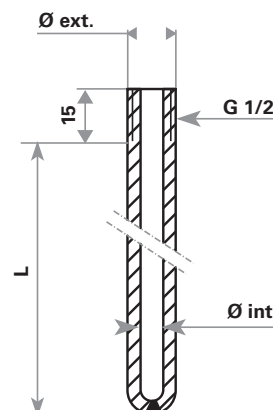

Bored metallic protectors

Models and codes for ordering

Material	External Ø	Thickness	Tap	Length	Code
Pure iron	30 mm	7 mm	G 1/2"	400 mm	LEL1485-003
				500 mm	LEL1485-009
				600 mm	LEL1485-010
				800 mm	LEL1485-002
				1000 mm	LEL1485-001
Cast iron	35 mm	12.75 mm	G 1/2"	300 mm	LEL1486-006
				400 mm	LEL1486-001
				500 mm	LEL1486-002
				600 mm	LEL1486-003
				700 mm	LEL1486-007
				750 mm	LEL1486-004
				900 mm	LEL1486-005

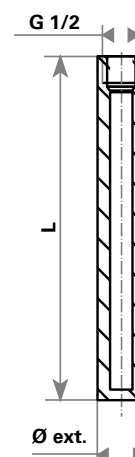

Screw-on bored tapered wells

Models and codes for ordering

Material	Ø of F threading	Ø under D threading	Ø of tap (electrical connection of sensor to the installation)	Length	Code
316L Stainless Steel	3/4" NPT	21 mm	1/2" NPT	100 mm	L403012-100
				150 mm	L403012-150
				200 mm	L403012-200
				250 mm	L403012-250
				300 mm	L403012-300
				350 mm	L403012-350
				400 mm	L403012-400
	1" NPT	26 mm	1/2" NPT	450 mm	L403012-450
				500 mm	L403012-500
				100 mm	L404012-100
				150 mm	L404012-150
				200 mm	L404012-200
				250 mm	L404012-250
				300 mm	L404012-300
			350 mm	L404012-350	
			400 mm	L404012-400	
			450 mm	L404012-450	
			500 mm	L404012-500	

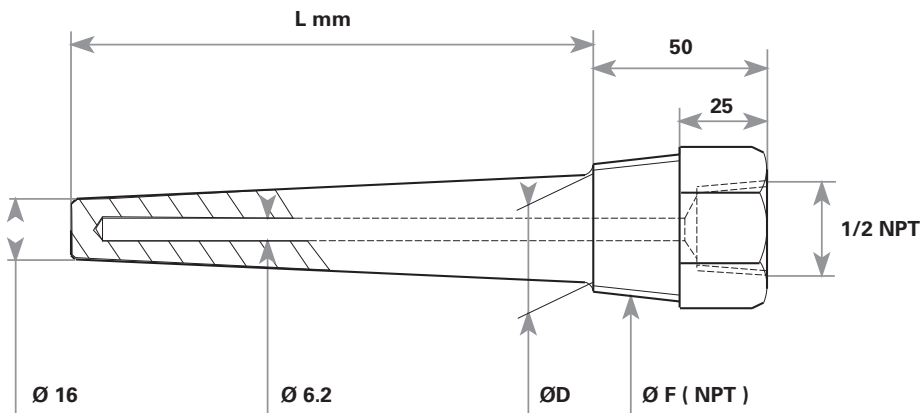

Adjustable compression fittings

Models and codes for ordering

Body material	Ferrule material	For sheath \varnothing	Threading	Code		
Stainless steel	Stainless steel	1.5 mm	1/8" NPT	L078827-000		
		2 mm	1/8" NPT	L078828-000		
		3 mm	1/8" NPT	L078829-000		
		3 mm	1/4" NPT	L078830-000		
		3.2 mm	1/4" NPT	L078834-000		
		4.5 mm	1/4" NPT	L078833-000		
		4.5 mm	1/2" NPT	L078934-000		
		6.0 mm	1/4" NPT	L078836-000		
		6.0 mm	1/2" NPT	L078938-000		
		6.0 mm	G1/2	L078946-000		
		6.35 mm	1/4" NPT	L078835-000		
		8.0 mm	1/4" NPT	L078841-000		
		8.0 mm	1/2" NPT	L078952-000		
		8.0 mm	G1/2	L078937-000		
		Brass	FEP	1.5 mm	1/8" NPT	L228123-000
				2.0 mm	1/8" NPT	L228124-000
3.0 mm	1/4" NPT			L228125-000		
3.0 mm	1/2" NPT			L078940-000		
4.5 mm	1/4" NPT			L228126-000		
5.0 mm	conical 3/8 G			L078849-000		
6.0 mm	1/4" NPT			L228127-000		
6.0 mm	conical 3/8 G			L078847-000		
6.0 mm	G1/2			L078838-000		
6.0 mm	1/2" NPT			L078939-000		
8.0 mm	1/4" NPT			L228128-000		
Brass	FEP			1.5 mm	1/8" NPT	L228143-000
		3.0 mm	1/4" NPT	L228145-000		
		3.2 mm	G1/8	L078948-000		
		4.5 mm	1/4" NPT	L228146-000		
		6.0 mm	G1/4	L078845-000		
	Brass	Brass	6.0 mm	1/4" NPT	L228147-000	
			8.0 mm	G3/8	L078846-000	
			1.5 mm	1/8" NPT	L078927-000	
			3.0 mm	1/4" NPT	L078930-000	
			6.0 mm	1/4" NPT	L078936-000	
		8.0 mm	1/4" NPT	L078941-000		

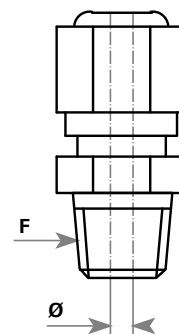

Spare ferrules

Models and codes for ordering

Material	For sheath \varnothing	Code
Stainless steel	1.5 mm	L228173-000
	3 mm	L228175-000
	4.5 mm	L228176-000
	6 mm	L228177-000
Brass	3 mm	L228185-000
	6 mm	L228187-000
	2 mm	L228194-000
FEP	3 mm	L078857-000
	4.5 mm	L078859-000
	6.0 mm	L078864-000
	8.0 mm	L078873-000



Adjustable compression fittings to be welded - food industry

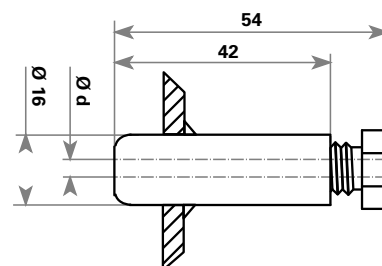
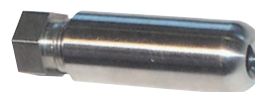

Models and codes for ordering

Material	Ferrule	For sheath Ø "d"	Length	Code
Stainless steel	Stainless steel	5.0 mm	54 mm	L228109-000
	Stainless steel	6.0 mm	54 mm	L228117-000

Bayonet connectors



Models and codes for ordering

Material	Threading	Length	Ø	Internal Ø of bayonet	Schema type	Code
Nickel-plated brass	M10x100	28 mm	10.3 mm	10.6 mm	A	P01.6050.27
	M10x150	28 mm	10.3 mm	10.6 mm		P01.6050.28
	M12x175	28 mm	10.3 mm	10.6 mm		P01.6050.30
	M12x100	35 mm	12 mm	12.5 mm	B	P01.6050.36
Stainless steel	M14x150	27 mm	14.5 mm	15.3 mm	C	P01.6050.38
	G3/8" cyl	27 mm	14.5 mm	15.3 mm		P01.6050.39

A type

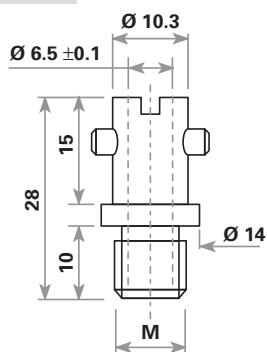

B type

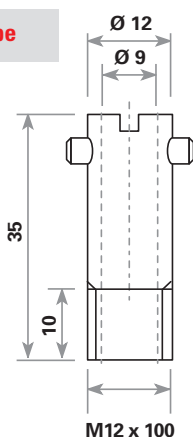

C type

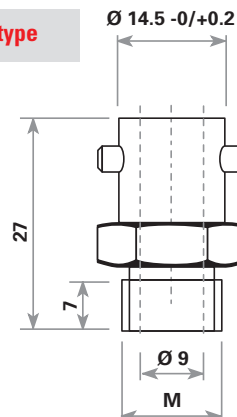

Support flanges for furnace assemblies: EBA adjustable flange

Models and codes for ordering

Details	Protector Ø	Material	Code
Flange	17.2 mm	Cast iron	LU77310-003
Flange	21 mm		L077311-000
Flange and counter-flange	22 mm		L077312-000
Flange	27 mm		L077314-000
Flange and counter-flange	27 mm		L077316-000
Flange	32 mm		L077319-000
Flange and counter-flange	32 mm		L077320-000



Flange

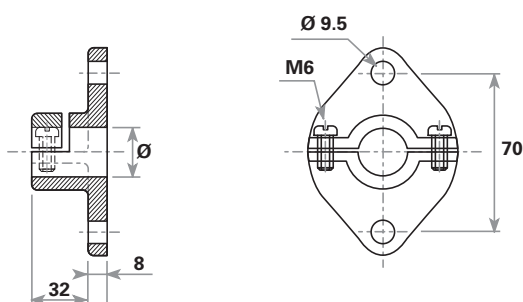

Counter-Flange

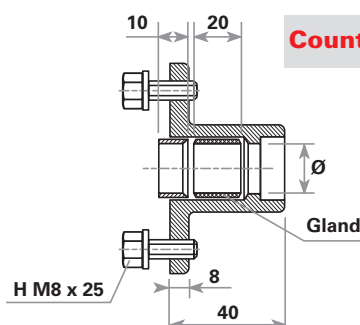

In-head transmitters



Models and codes for ordering

Output signal	Method of protection	Input	Code
4-20 mA	Standard	Universal: RTD 100 Ω/all thermocouples	LC5331A-311
		RTD 100 Ω	LC5333A-100
		All thermocouples	LC5334A-100
4-20 mA HART	ATEX EEx"i"a	Universal: RTD 100 Ω/all thermocouples	LC5331B-221
		RTD 100 Ω	LC5333B-100
		Universal: RTD 100 Ω/all thermocouples	LC5335A-100
4-20 mA HART	ATEX EEx"i"a	Universal: RTD 100 Ω/all thermocouples	LC5335B-100

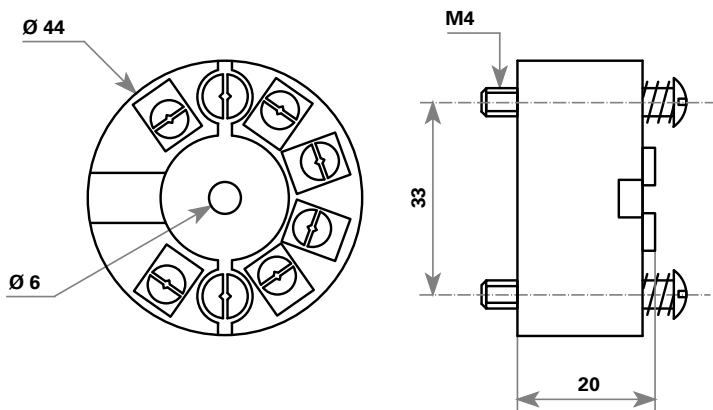

Programming kit

Code for ordering

LC59050-000



Pyro-Contrôle sensors

for the most demanding industries, from $-268\text{ }^{\circ}\text{C}$ to $+1.700\text{ }^{\circ}\text{C}$

CHEMICALS, PETROCHEMICALS

These industries are characterised by highly stringent safety requirements. Our daily business consists of manufacturing thimbles in stainless steel, nickel, PVDF, PTFE, and Hastelloy, or coated in tantalum. We can manufacture all skin thermocouples, multi-point assemblies, "i", "e" and "d" safety probes according to your requirements.



ELECTRONICS INDUSTRY

Multi-point thermocouples and spikes must be of the utmost purity. When wafers are manufactured, P and N doping and substrate oxidations will not tolerate even the slightest contamination.



METALLURGY, IRONWORKS

For the high temperatures of these industries, each sensor is adapted to the environment measured. K, S, R or B thermocouples, according to temperature range, and stainless steel, refractories, ceramic, composite or pure alumina protectors.



POWER AND NUCLEAR INDUSTRIES

Our KI qualified probes equip primary fluid bearings in nuclear reactors. In traditional fuel-oil or gas boilers and thermal power stations, our suction thermocouples for flame temperature measure directly at the heart of the burners' flames. Our sensors can be used for temperatures up to and exceeding $1,700\text{ }^{\circ}\text{C}$.



AERONAUTICS AND RAIL INDUSTRY

The extreme operating conditions - especially severe vibrations - experienced in these industries, are taken into account when defining sensors that are specifically adapted for mechanical requirements.

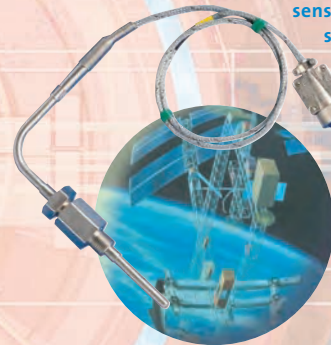

GLASS INDUSTRY

Vault and bottom thermocouple assemblies for melting furnaces and rhodium-coated platinum sheathed 3 or 5 point insertion feeder pyrometers are manufactured with the level of care appropriate for such high purity materials. Trade-in of precious metal scrap is guaranteed.



PHARMACY, AGRI-FOOD

Our sensors meet the cleanliness and materials compatibility requirements of these industries. These sensors must resist pressure and humidity in sterilizers and autoclaves.



Pyro-Contrôle calibration materials and services

- COFRAC Calibration accreditation n° 2-1385
- From $-20\text{ }^{\circ}\text{C}$ to $+450\text{ }^{\circ}\text{C}$ for RTD $100\ \Omega$ probes and from $-20\text{ }^{\circ}\text{C}$ to $+1,550\text{ }^{\circ}\text{C}$ for thermocouples.
- Temperature sensors
- Fixed point temperature cells
- Calibration furnaces
- Surfalcal® surface temperature reference

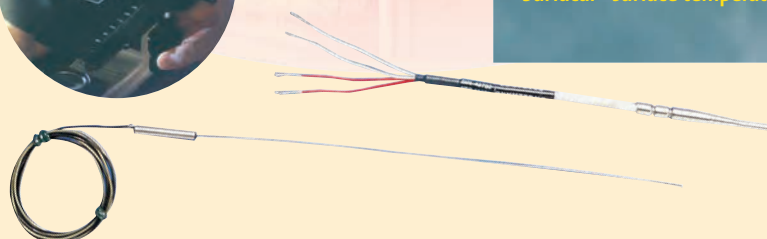

For total control of the thermal process line



Temperature transmitters
For conditioning all temperature and process signals, a range of converters and transmitters, 1 or 2 channels, analogue or digital output, ...



Bluetooth radio modem/RS485
Wireless communication, reliable and safe. Replaces RS485/RS232 wire connections. Bluetooth® technology.

Signal transmission



Temperature controllers
A broad range of digital and analogue controllers, simple or elaborate models. Several formats, single or multi-input, ...

Signal processing



Power blocks with thyristors
A range of thyristor power controllers, from 8 A to 2,900 A. Single or three-phase, for resistive and inductive loads. Several control and monitoring functions, ...

Electric actuator



Digital panel meters
Several programmable digital panel meters for temperature and process signals. Memorisation of minimum and maximum values, ...



Recorders
Paperless model with very high definition video screen, up to 18 configurable measurement channels, PC software data processing, ...

Display monitoring



Help service
Commissioning, training, ...

Setting up

Don't hesitate
to contact **Pyro-Contrôle**





CHAUVIN ARNOUX
Test and Measurement
190, rue Championnet
75876 PARIS Cedex 18
FRANCE
Tel.: +33 1 44 85 44 85
Fax: +33 1 46 27 73 89
info@chauvin-arnoux.fr
www.chauvin-arnoux.com

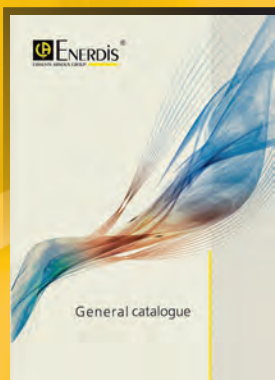

ENERDIS
16, rue Georges Besse - Silic 44
92182 ANTONY Cedex
FRANCE
Tel.: +33 1 75 60 10 30
Fax: +33 1 46 66 62 54
info@enerdis.fr
www.enerdis.fr



MANUMASURE
Reux
14130 PONT L'ÉVÊQUE
FRANCE
Tél.: +33 2 31 64 51 55
Fax.: +33 2 31 64 51 52
info@manumasure.fr
www.manumasure.fr

10 SUBSIDIARIES WORLDWIDE

GERMANY

Chauvin Arnoux GmbH
Straßburger Str. 34
77694 KEHL / RHEIN
Tel.: +49 07851 99 26-0
Fax: +49 07851 99 26-60
info@chauvin-arnoux.de
www.chauvin-arnoux.de

AUSTRIA

Chauvin Arnoux Ges.m.b.H
Slamastrasse 29/2/4
1230 WIEN
Tel.: +43 1 61 61 9 61
Fax: +43 1 61 61 9 61-61
vie-office@chauvin-arnoux.at
www.chauvin-arnoux.at

CHINA

Shanghai Pu-Jiang
Enerdis Instruments Co. Ltd
3 F, 3 rd Building
N° 381 Xiang De Road
200081 SHANGHAI
Tel.: +86 21 65 21 51 96
Fax: +86 21 65 21 61 07
info@chauvin-arnoux.com.cn

SPAIN

Chauvin Arnoux Iberica SA
C/ Roger de Flor N°293, 1a
Planta
08025 BARCELONA
Tel.: +34 902 20 22 26
Fax: +34 93 459 14 43
comercial@chauvin-arnoux.es
www.chauvin-arnoux.es

ITALY

AMRA SpA
Via S. Ambrogio, 23
20846 MACHERIO (MB)
Tel.: +39 039 245 75 45
Fax: +39 039 481 561
info@amra-chauvin-arnoux.it
www.chauvin-arnoux.it

MIDDLE EAST

Chauvin Arnoux Middle East
PO Box 60-154
1241 2020 JAL EL DIB
(Beirut) - LEBANON
Tel.: +961 1 890 425
Fax: +961 1 890 424
camie@chauvin-arnoux.com
www.chauvin-arnoux.com

UNITED KINGDOM

Chauvin Arnoux Ltd
Unit 1 Nelson Ct, Flagship Sq
Shaw Cross Business Pk, Dewsbury
West Yorkshire - WF12 7TH
Tel: +44 1924 460 494
Fax: +44 1924 455 328
info@chauvin-arnoux.co.uk
www.chauvin-arnoux.com

SCANDINAVIA

CA Mätssystem AB
Box 4501
SE 18304 Täby
Tel.: +46 8 50 52 68 00
Fax: +46 8 50 52 68 10
info@camatsystem.com
www.camatsystem.com

SWITZERLAND

Chauvin Arnoux AG
Moosacherstrasse 15
8804 AU / ZH
Tel.: +41 44 727 75 55
Fax: +41 44 727 75 56
info@chauvin-arnoux.ch
www.chauvin-arnoux.ch

USA

Chauvin Arnoux Inc
d.b.a AEMC Instruments
200 Foxborough Blvd.
Foxborough - MA 02035
Tel.: +1 (508) 698-2115
Fax: +1 (508) 698-2118
sales@aemc.com
www.aemc.com

Central contact

PYROCONTROLE

6 bis av du Docteur Schweitzer
69881 MEYZIEU Cedex
Tel.: +33 4 72 14 15 55
Fax.: +33 4 72 14 15 41
export@pyro-controle.tm.fr
www.pyro-controle.com

FRANCE
Pyrocontrole
6 bis, av du Docteur Schweitzer
69881 MEYZIEU Cedex
Tel: +33 4 72 14 15 55
Fax: +33 4 72 14 15 41
infot@pyro-controle.tm.fr
www.pyro-controle.com

UNITED KINGDOM
Chauvin Arnoux Ltd
Unit 1 Nelson Ct, Flagship Sq, Shaw Cross
Business Pk
Dewsbury, West Yorkshire - WF12 7TH
Tel: +44 1924 460 494
Fax: +44 1924 455 328
info@chauvin-arnoux.co.uk
www.chauvin-arnoux.com

Middle East
Chauvin Arnoux Middle East
P.O. BOX 60-154
1241 2020 JAL EL DIB - LEBANON
Tel: +961 1 890 425
Fax: +961 1 890 424
camie@chauvin-arnoux.com
www.chauvin-arnoux.com

